

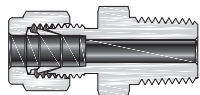

Обжимные фитинги

Двухкольцевые

Содержание



Штуцер с внешней резьбой

8

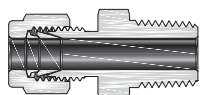

Фитинги с внешней резьбой для термопар

21

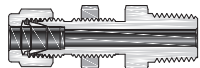

Штуцер с внешней резьбой и монтажом на панель

23

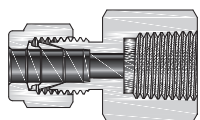

Фитинг с внутренней резьбой

25

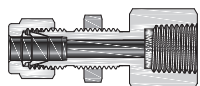

Фитинг с внутренней резьбой с креплением на панель

30

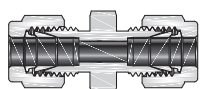

Муфты

3F

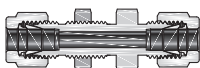

Муфты с монтажом на панель

31

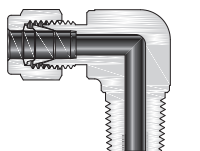

Угольник с внешней резьбой

35

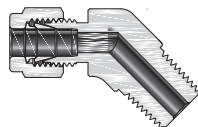

Угольник под 45° с внешней резьбой

38

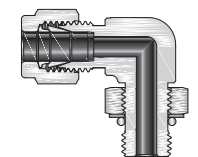

Позиционируемый угольник с внешней резьбой

39

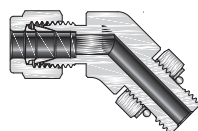

Позиционируемый угольник под 45° с внутренней резьбой

41

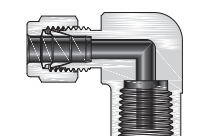

Угольник с внутренней резьбой

42

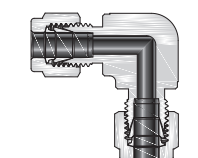

Соединительный угольник

43

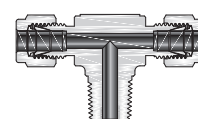

Тройник с внешней резьбой снизу

45

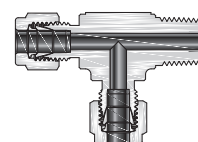

Тройник с внешней резьбой сбоку

46

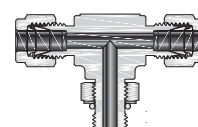

Позиционируемый тройник с внешней резьбой снизу

47

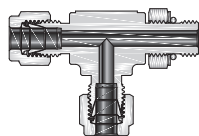

Позиционируемый тройник с внешней резьбой сбоку

47

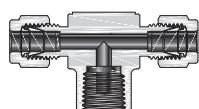

Тройник с внутренней резьбой снизу

49

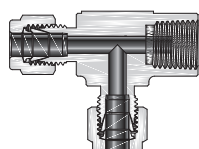

Тройник с внутренней резьбой сбоку

50

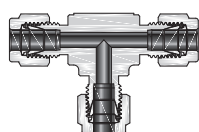

Соединительный тройник

51

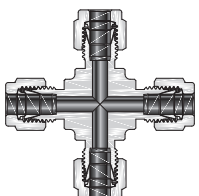

Соединительная крестовина

54

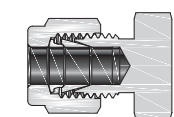

Колпак

55

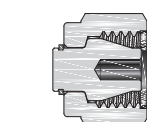

Заглушка

55

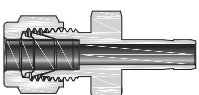

Переходник с трубным адаптером

56



Соединитель для фитингов

58

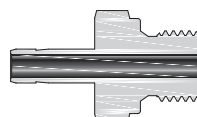

Трубный адаптер с внешней резьбой

59

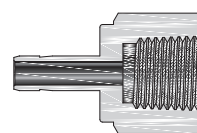

Трубный адаптер с внутренней резьбой

64

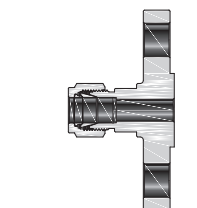

Фланцевый переходник

67

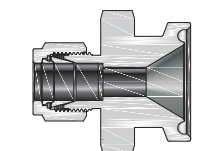

Переходник с санитарного фланца

68

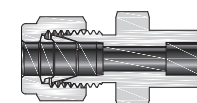

Штуцер под приварку

69

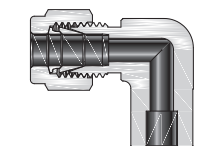

Угольник под приварку



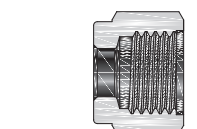





70

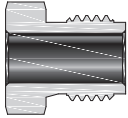

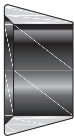
Гайка

71

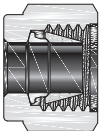
Содержание

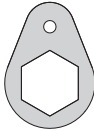
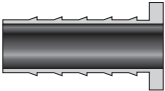
	Гайки		Комбинированные уплотнительные кольца
72		75	
	Передние обжимные кольца		Уплотнительные медные кольца для внешней резьбы
72		75	
	Задние обжимные кольца		Уплотнительные медные кольца для манометрической резьбы
72		76	
	Комплект обжимных колец и гайки		Уплотнительные кольца из эластомеров
73		77	
	Набор обжимных колец		Фиксатор для монтажа на панель
73		78	
	Вставки для мягких трубок		
74			

Характеристики

- ❖ Обжимные фитинги уплотняются металл по металлу без использования каких-либо эластомеров
- ❖ Обжимные фитинги CIR-LOK спроектированы для работы при давлении значительно превышающем давление трубки
- ❖ Стандартный дизайн для всего диапазона размеров трубок
- ❖ Жёсткость трубок не должна превышать 85 по Роквеллу
- ❖ Доступны размеры фитингов от 1/16 до 2 дюймов и от 2 до 50 мм.
- ❖ Фитинги могут быть изготовлены из нержавеющей стали, углеродистой стали, латуни, алюминия, Хастеллоя, Инкоя и других сплавов.
- ❖ Подсеребрённая резьба на гайке фитинга для уменьшения усилия при затяжке и исключения эффекта холодной сварки.
- ❖ Фитинги прекрасно работают в вакуумных системах и в системах с сильной вибрацией.

Производительность

- ❖ Гидравлический тест (превышение рабочего давления в 1.5 раза): утечек нет
- ❖ Сборка разборка фитингов 50 раз: утечек нет
- ❖ Тест на четырёхкратное превышение давления: утечек нет
- ❖ Тестирование вакуумом при $1 \cdot 10^{-8}$: утечки нет
- ❖ Тестирование азотом при полуторакратном превышении давления: утечек нет
- ❖ Тестирование с импульсной и вибрационной нагрузкой (импульсы 0,5 - 1.7 Гц, вибрация 23-47 Гц): Утечек нет
- ❖ Тест на термоцикличность. Нагрев системы до +80 °С резкое охлаждение до -25 °С и тест на герметичность: утечек нет
- ❖ Герметичность при вибрации. Система вибрирует с частотой 45 Гц под давлением $20 \cdot 10^6$ циклов: утечек нет
- ❖ Воздействие открытым огнём (согласно стандарту BS ISO 19921): утечек нет
- ❖ Тест на коррозию в течении 168ч: Видимых следов коррозии нет
- ❖ Подводный тест (эквивалент глубины 3048): Утечки гелия нет

Стандартные используемые материалы

Материал	Заготовка ⁽¹⁾	Поковки ⁽²⁾
Нержавеющая сталь марки 316	ASTM A276 ASME SA479, EN 1.4401	ASTM A182 ASME SA182, EN 1.4401
Сплав 20	ASTM B473	ASTM B462
Сплав 400/R-405	ASTM B164, ASME SB164	ASTM B564, ASME SB564
Сплав 600	ASTM B166, ASME SB166	ASTM B564, ASME SB564
Сплав 625	ASTM B446 ⁽³⁾	ASTM B564, ASMESB564 ⁽⁴⁾
Сплав 825	ASTM B425	ASTM B564, ASME SB564
Сплав C-276	ASTM B574	ASTM B564
Алюминий	ASTM B211	ASTM B247
Латунь	ASTM B16 ASTM B453	ASTM B283
Углеродистая сталь ⁽⁵⁾	ASTM A108	—
Дуплекс 2507	ASTM A479	ASTM A182
Титан	ASTM B348	ASTM B381
Тефлон (PFA)	—	ASTM D3307 Type I
Тефлон (PTFE)	ASTM D1710	ASTM D3294

- ① Прямые фитинги и переходники для трубок
- ② Отводы, крестовины и тройники
- ③ Все прямые фитинги и переходники для трубок диаметром 1/4 и 3/8 дюйма; Отводы, крестовины и тройники диаметром 6 и 10 мм.
- ④ Отводы, крестовины и тройники диаметром более 3/8 дюйма и 10 мм.
- ⑤ Все трубные фитинги CIR-LOK из углеродистой стали поставляются с задними обжимными кольцами из нержавеющей стали 316.

Спецификация по резьбам

Тип резьбы	Справочная спецификация
NPT	ASME B1.20.1, SAE AS71051
ISO/BSP(Цилиндрическая) (На основе DIN 3852) (Фитинги CIR-LOK PPT, BP и BS)	ISO 7-1, BS EN 10226-1, JIS B0203
ISO/BSP(Коническая) (На основе DIN 3852) (Фитинги CIR-LOK BT)	ISO 228-1, JIS B0202
Унифицированная (SAE) (CIR-LOK SA фитинги)	ASME B1.1
Метрическая	ISO 261

Параметры рабочей температуры

Материал	Рабочая температура, °F (°C)
Нерж. ст. 316	-321 (-196) до 1200 (649)
Латунь	-321 (-196) до 400 (204)
Углеродистая сталь	-65 (-53) до 375 (190)
Прокладки BS (FKM)	-5 (-15) до 400 (204)
Прокладки BG BP (медь)	-325 (-198) до 1200 (649)
Уплотнительные кольца SAE (FKM)	-20 (-28) до 400 (204)

❖ Температура системы может быть ограничена герметиком для резьбы или, если применимо, материалом прокладки или уплотнительного кольца.

Герметики для трубной резьбы

❖ При сборке конической резьбы всегда следует использовать герметик резьбы или ленту из PTFE.

Метрические трубные фитинги CIR-LOK

❖ Метрические и дюймовые трубные фитинги внешне схожи. Во избежание путаницы и для облегчения идентификации трубные фитинги с метрической резьбой имеют ступенчатый выступ на шестиграннике корпуса и шестигранную гайку.

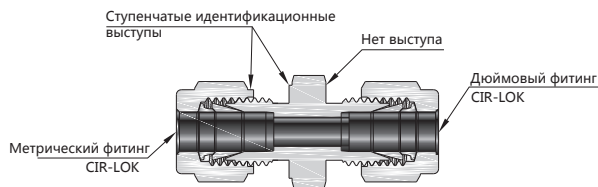

Параметры давления трубных фитингов CIR-LOK

❖ Концы трубных фитингов CIR-LOK рассчитаны на рабочее давление трубок, указанное в данных о трубках CIR-LOK.

Рабочее давление резьбы NPT/ISO

❖ Давление при комнатной температуре по стандарту ASME B31.3

Размер трубы NPT/ISO	Нержавеющая и углеродистая сталь				Латунь			
	Внешняя		Внутренняя		Внешняя		Внутренняя	
	фунт/кв. дюйм	Бар	фунт/кв. дюйм	Бар	фунт/кв. дюйм	Бар	фунт/кв. дюйм	Бар
1/16	11000	760	6700	460	5500	380	3300	230
1/8	10000	690	6500	440	5000	340	3200	220
1/4	8000	550	6600	450	4000	270	3300	220
3/8	7800	540	5300	360	3900	270	2600	180
1/2	7700	530	4900	330	3800	260	2400	160
3/4	7300	500	4600	320	3600	250	2300	160
1	5300	370	4400	300	2600	180	2200	150
1 1/4	6000	410	5000	350	3000	200	2500	170
1 1/2	5000	340	4600	310	2500	170	2300	150
2	3900	270	3900	270	1900	130	1900	130

Для уточнения давлений по стандарту ASME B31.1:
 Для нержавеющей стали коэффициент 0,94
 Для углеродистой стали коэффициент 0,85
 Для Латунни коэффициент остаётся тем же.

Унифицированная резьба SAE/MS

Рабочие давления по стандарту SAE J1926/3

SAE/MS Размер резьбы	Нержавеющая и углеродистая сталь			
	Непозиционируемые		Позиционируемые	
	фунт/кв. дюйм	Бар	фунт/кв. дюйм	Бар
5/16-24	4568	315	4568	315
7/16-20				
1/2-20				
9/16-18			3626	250
3/4-16				
7/8-14	3626	250	2900	200
1 1/16-12				
1 3/16-12	2900	200	2320	160
1 5/16-12				
1 5/8-12	2320	160	1813	125
1 7/8-12				
2 1/2-12	1813	125	1450	100

Фитинги с уплотнительным кольцом из эластомеров имеют меньшие рабочие давления.

Позиционируемые, ISO/ BSP Рабочее давление

Давления при комнатной температуре

ISO/BSPP Размер внешней трубы, дюйм	Нержавеющая и углеродистая сталь	
	фунт/кв. дюйм	Бар
1/8	4568	315
1/4		
3/8		
1/2	2320	160
3/4		
1		

Виды уплотнения цилиндрических резьб

1. Уплотнение комбинированной прокладкой

- Внешняя резьба по стандарту DIN 3852-2 тип A
- Внутренняя резьба по стандарту DIN 3852-2 тип X

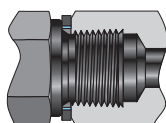

2. Уплотнение медной прокладкой

- Внешнее уплотнение по стандарту DIN 3852-2 тип B
- Внутреннее уплотнение по стандарту DIN 3852-2 тип X
- Медные прокладки используются только с фитингами типа BS.

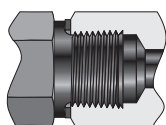

3. Уплотнение манометрических резьб медными кольцами

- Медные прокладки используются только с фитингами типа BS.

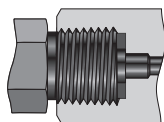

4. Уплотнение позиционируемой резьбы

- Внешнее уплотнение по стандарту DIN 3852-2 тип X

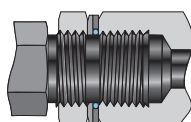

Штуцер с внешней резьбой

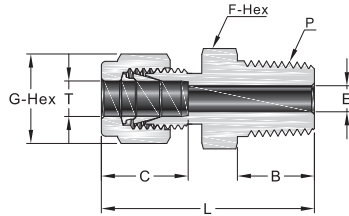

Дюймовая трубка

Резьба NPT

Трубка, дюйм	Резьба P-NPT	Артикул для заказа	Размеры, мм					
			L	B	C	E	G	F
1/16	1/16	F1-MC-NPT1-	23.9	9.7	8.6	1.3	7.9	7.9
1/16	1/8	F1-MC-NPT2-	26.2	9.7	8.6	1.3	7.9	11.1
1/16	1/4	F1-MC-NPT4-	31.0	14.2	8.6	1.3	7.9	14.3
1/8	1/16	F2-MC-NPT1-	29.7	9.7	12.7	2.3	11.1	11.1
1/8	1/8	F2-MC-NPT2-	30.5	9.7	12.7	2.3	11.1	11.1
1/8	1/4	F2-MC-NPT4-	35.6	14.2	12.7	2.3	11.1	14.3
1/8	3/8	F2-MC-NPT6-	35.8	14.2	12.7	2.3	11.1	17.5
1/8	1/2	F2-MC-NPT8-	42.2	19.1	12.7	2.3	11.1	22.2
3/16	1/16	F3-MC-NPT1-	31.2	9.7	13.7	2.3	12.7	11.1
3/16	1/8	F3-MC-NPT2-	31.2	9.7	13.7	3.0	12.7	11.1
3/16	1/4	F3-MC-NPT4-	36.3	14.2	13.7	3.0	12.7	14.3
1/4	1/16	F4-MC-NPT1-	32.8	9.7	15.2	3.0	14.3	12.7
1/4	1/8	F4-MC-NPT2-	32.8	9.7	15.2	4.8	14.3	12.7
1/4	1/4	F4-MC-NPT4-	37.8	14.2	15.2	4.8	14.3	14.3
1/4	3/8	F4-MC-NPT6-	38.4	14.2	15.2	4.8	14.3	17.5
1/4	1/2	F4-MC-NPT8-	44.7	19.1	15.2	4.8	14.3	22.2
1/4	3/4	F4-MC-NPT12-	46.2	19.1	15.2	4.8	14.3	27.0
5/16	1/8	F5-MC-NPT2-	34.0	9.7	16.3	4.8	15.9	14.3
5/16	1/4	F5-MC-NPT4-	38.6	9.7	16.3	6.4	15.9	14.3
5/16	3/8	F5-MC-NPT6-	39.1	14.2	16.3	6.4	15.9	17.5
5/16	1/2	F5-MC-NPT8-	45.5	19.1	16.3	6.4	15.9	22.2
3/8	1/8	F6-MC-NPT2-	35.3	9.7	16.8	4.8	17.5	15.9
3/8	1/4	F6-MC-NPT4-	39.9	14.2	16.8	7.1	17.5	15.9
3/8	3/8	F6-MC-NPT6-	39.9	14.2	16.8	7.1	17.5	17.5
3/8	1/2	F6-MC-NPT8-	46.2	19.1	16.8	7.1	17.5	22.2
3/8	3/4	F6-MC-NPT12-	47.8	19.1	16.8	7.1	17.5	27.0
3/8	1	F6-MC-NPT16-	47.0	23.9	16.8	7.1	17.5	34.9
1/2	1/8	F8-MC-NPT2-	38.9	9.7	22.9	4.8	22.2	20.6
1/2	1/4	F8-MC-NPT4-	43.4	14.2	22.9	7.1	22.2	20.6
1/2	3/8	F8-MC-NPT6-	43.4	14.2	22.9	9.7	22.2	20.6
1/2	1/2	F8-MC-NPT8-	49.0	19.1	22.9	10.4	22.2	22.2
1/2	3/4	F8-MC-NPT12-	50.5	19.1	22.9	10.4	22.2	27.0
1/2	1	F8-MC-NPT16-	57.2	23.9	22.9	10.4	22.2	34.9
5/8	1/4	F10-MC-NPT4-	44.2	14.2	24.4	7.1	25.4	23.8
5/8	3/8	F10-MC-NPT6-	44.2	14.2	24.4	9.7	25.4	23.8
5/8	1/2	F10-MC-NPT8-	49.0	19.1	24.4	11.9	25.4	23.8
5/8	3/4	F10-MC-NPT12-	50.5	19.1	24.4	12.7	25.4	27.0
3/4	3/8	F12-MC-NPT6-	45.7	14.2	24.4	10.4	28.6	27.0
3/4	1/2	F12-MC-NPT8-	50.5	19.1	24.4	11.9	28.6	27.0
3/4	3/4	F12-MC-NPT12-	50.5	19.1	24.4	15.7	28.6	27.0
3/4	1	F12-MC-NPT16-	57.2	23.9	24.4	15.7	28.6	34.9
7/8	1/2	F14-MC-NPT8-	50.5	19.1	25.9	11.9	31.8	30.2
7/8	3/4	F14-MC-NPT12-	50.5	19.1	25.9	15.7	31.8	30.2
7/8	1	F14-MC-NPT16-	57.2	23.9	25.9	18.3	31.8	34.9
1	1/2	F16-MC-NPT8-	57.4	19.1	31.2	11.9	38.1	34.9
1	3/4	F16-MC-NPT12-	57.4	19.1	31.2	15.7	38.1	34.9
1	1	F16-MC-NPT16-	62.2	23.9	31.2	22.4	38.1	34.9
1 1/8	1	F18-MC-NPT16-	62.2	23.9	31.2	22.4	46.0	41.3
1 1/4	1	F20-MC-NPT16-	77.2	23.9	41.1	22.4	47.6	44.5
1 1/4	1 1/4	F20-MC-NPT20-	77.2	23.9	41.1	27.7	47.6	44.5
1 1/2	1 1/2	F24-MC-NPT24-	88.9	26.2	50.0	34.0	57.2	54.0

Штуцер с внешней резьбой

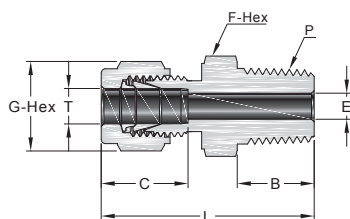

Метрическая трубка

Резьба NPT

Трубка, мм	P-NPT Резьба	Артикул для заказа	Размеры, мм					
			L	B	C	E	G	F
2	1/8	M2-MC-NPT2-	30.5	9.7	12.9	1.7	12	12
3	1/8	M3-MC-NPT2-	30.5	9.7	12.9	2.4	12	12
3	1/4	M3-MC-NPT4-	35.6	14.2	12.9	2.4	12	14
4	1/8	M4-MC-NPT2-	31.2	9.7	13.7	2.4	12	12
4	1/4	M4-MC-NPT4-	36.3	14.2	13.7	2.4	12	14
6	1/8	M6-MC-NPT2-	32.8	9.7	15.3	4.8	14	14
6	1/4	M6-MC-NPT4-	37.9	14.2	15.3	4.8	14	14
6	3/8	M6-MC-NPT6-	38.4	14.2	15.3	4.8	14	18
6	1/2	M6-MC-NPT8-	44.7	19.1	15.3	4.8	14	22
8	1/8	M8-MC-NPT2-	34.2	9.7	16.2	4.8	16	15
8	1/4	M8-MC-NPT4-	38.7	14.2	16.2	6.4	16	15
8	3/8	M8-MC-NPT6-	39.3	14.2	16.2	6.4	16	18
8	1/2	M8-MC-NPT8-	45.6	19.1	16.2	6.4	16	22
10	1/8	M10-MC-NPT2-	36.3	9.7	17.2	4.8	19	18
10	1/4	M10-MC-NPT4-	40.9	14.2	17.2	7.1	19	18
10	3/8	M10-MC-NPT6-	40.9	14.2	17.2	7.9	19	18
10	1/2	M10-MC-NPT8-	46.5	19.1	17.2	7.9	19	22
10	3/4	M10-MC-NPT12-	48.0	19.1	17.2	7.9	19	27
10	1	M10-MC-NPT16-	54.6	23.9	17.2	7.9	19	35
12	1/8	M12-MC-NPT2-	38.8	9.7	22.8	4.8	22	22
12	1/4	M12-MC-NPT4-	43.4	14.2	22.8	7.1	22	22
12	3/8	M12-MC-NPT6-	43.4	14.2	22.8	9.5	22	22
12	1/2	M12-MC-NPT8-	49.0	19.1	22.8	9.5	22	22
12	3/4	M12-MC-NPT12-	50.5	19.1	22.8	9.5	22	27
14	1/8	M14-MC-NPT2-	38.8	9.7	24.4	4.8	25	24
14	1/4	M14-MC-NPT4-	44.1	14.2	24.4	7.1	25	24
14	3/8	M14-MC-NPT6-	44.1	14.2	24.4	9.5	25	24
14	1/2	M14-MC-NPT8-	49.0	19.1	24.4	11.1	25	24
14	3/4	M14-MC-NPT12-	50.5	19.1	24.4	11.1	25	27
15	1/2	M15-MC-NPT8-	49.0	19.1	24.4	11.9	25	24
15	3/4	M15-MC-NPT12-	50.5	19.1	24.4	11.9	25	27
15	1	M15-MC-NPT16-	57.1	23.9	24.4	11.9	25	35
16	1/4	M16-MC-NPT4-	44.1	14.2	24.4	7.1	25	24
16	3/8	M16-MC-NPT6-	44.1	14.2	24.4	9.5	25	24
16	1/2	M16-MC-NPT8-	49.0	19.1	24.4	11.9	25	24
16	3/4	M16-MC-NPT12-	50.5	19.1	24.4	12.7	25	27
18	3/8	M18-MC-NPT6-	45.6	14.2	24.4	9.5	30	27
18	1/2	M18-MC-NPT8-	50.5	19.1	24.4	11.9	30	27
18	3/4	M18-MC-NPT12-	50.5	19.1	24.4	15.1	30	27
20	1/2	M20-MC-NPT8-	52.3	19.1	26.0	11.9	32	30
20	3/4	M20-MC-NPT12-	52.3	19.1	26.0	15.9	32	30
20	1	M20-MC-NPT16-	57.1	23.9	26.0	15.9	32	35
22	1/2	M22-MC-NPT8-	52.3	19.1	26.0	11.9	32	30
22	3/4	M22-MC-NPT12-	52.3	19.1	26.0	15.9	32	30
22	1	M22-MC-NPT16-	57.1	23.9	26.0	18.3	32	35
25	1/2	M25-MC-NPT8-	57.5	19.1	31.3	11.9	38	35
25	3/4	M25-MC-NPT12-	57.5	19.1	31.3	15.9	38	35
25	1	M25-MC-NPT16-	62.3	23.9	31.3	21.8	38	35
28	1	M28-MC-NPT16-	72.4	23.9	36.6	21.8	46	41
28	1 1/4	M28-MC-NPT20-	73.1	23.9	36.6	21.8	46	46
30	1 1/4	M30-MC-NPT20-	77.2	23.9	39.6	26.2	50	46
32	1 1/4	M32-MC-NPT20-	79.6	23.9	42.0	28.6	50	46
38	1 1/2	M38-MC-NPT24-	91.6	26.2	49.4	33.7	60	55

Штуцер с внешней резьбой

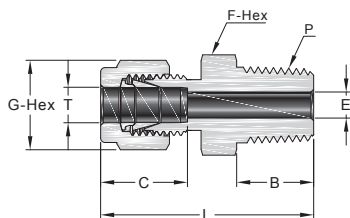

Дюймовая трубка

Коническая резьба ISO (BSPT)

Трубка, дюйм	P-BSPT Резьба	Артикул для заказа	Размеры, мм					
			L	B	C	E	G	F
1/8	1/8	F2-MC-MBT2-	30.5	9.7	12.7	2.3	11.1	11.1
1/8	1/4	F2-MC-MBT4-	35.6	14.2	12.7	2.3	11.1	14.3
1/4	1/8	F4-MC-MBT2-	32.8	9.7	15.2	4.8	14.3	12.7
1/4	1/4	F4-MC-MBT4-	37.8	14.2	15.2	4.8	14.3	14.3
1/4	3/8	F4-MC-MBT6-	38.4	14.2	15.2	4.8	14.3	17.5
1/4	1/2	F4-MC-MBT8-	44.7	19.1	15.2	4.8	14.3	22.2
5/16	1/8	F5-MC-MBT2-	34.0	9.7	16.3	4.8	15.9	14.3
5/16	1/4	F5-MC-MBT4-	38.6	9.7	16.3	6.4	15.9	14.3
3/8	1/8	F6-MC-MBT2-	35.3	9.7	16.8	4.8	17.5	15.9
3/8	1/4	F6-MC-MBT4-	39.9	14.2	16.8	7.1	17.5	15.9
3/8	3/8	F6-MC-MBT6-	39.9	14.2	16.8	7.1	17.5	17.5
3/8	1/2	F6-MC-MBT8-	46.2	19.1	16.8	7.1	17.5	22.2
3/8	3/4	F6-MC-MBT12-	47.8	19.1	16.8	7.1	17.5	27.0
1/2	1/4	F8-MC-MBT4-	43.4	14.2	22.9	7.1	22.2	20.6
1/2	3/8	F8-MC-MBT6-	43.4	14.2	22.9	9.7	22.2	20.6
1/2	1/2	F8-MC-MBT8-	49.0	19.1	22.9	10.4	22.2	22.2
1/2	3/4	F8-MC-MBT12-	50.5	19.1	22.9	10.4	22.2	27.0
5/8	1/2	F10-MC-MBT8-	49.0	19.1	24.4	11.9	25.4	23.8
3/4	3/4	F12-MC-MBT12-	50.5	19.1	24.4	15.7	28.6	27.0
3/4	1	F12-MC-MBT16-	57.2	23.9	24.4	15.7	28.6	34.9
1	3/4	F16-MC-MBT12-	57.4	19.1	31.2	15.7	38.1	34.9
1	1	F16-MC-MBT16-	62.2	23.9	31.2	22.4	38.1	34.9

Штуцер с внешней резьбой

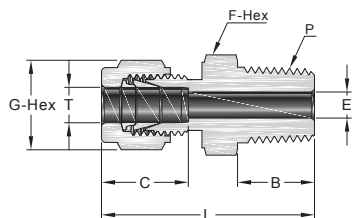

Метрическая трубка

Коническая резьба ISO (BSPT)

Трубка, мм	P-BSPT Резьба	Артикул для заказа	Размеры, мм					
			L	B	C	E	G	F
2	1/8	M2-МС-MBT2-	30.5	9.7	12.9	1.7	12	12
3	1/8	M3-МС-MBT2-	30.5	9.7	12.9	2.4	12	12
3	1/4	M3-МС-MBT4-	35.6	14.2	12.9	2.4	12	14
4	1/8	M4-МС-MBT2-	31.2	9.7	13.7	2.4	12	12
4	1/4	M4-МС-MBT4-	36.3	14.2	13.7	2.4	12	14
6	1/8	M6-МС-MBT2-	32.8	9.7	15.3	4.8	14	14
6	1/4	M6-МС-MBT4-	37.9	14.2	15.3	4.8	14	14
6	3/8	M6-МС-MBT6-	38.4	14.2	15.3	4.8	14	18
6	1/2	M6-МС-MBT8-	44.7	19.1	15.3	4.8	14	22
8	1/8	M8-МС-MBT2-	34.2	9.7	16.2	4.8	16	15
8	1/4	M8-МС-MBT4-	38.7	14.2	16.2	6.4	16	15
8	3/8	M8-МС-MBT6-	39.2	14.2	16.2	6.4	16	18
8	1/2	M8-МС-MBT8-	45.6	19.1	16.2	6.4	16	22
10	1/8	M10-МС-MBT2-	36.3	9.7	17.2	4.8	19	18
10	1/4	M10-МС-MBT4-	40.9	14.2	17.2	7.1	19	18
10	3/8	M10-МС-MBT6-	40.9	14.2	17.2	7.9	19	18
10	1/2	M10-МС-MBT8-	46.5	19.1	17.2	7.9	19	22
10	3/4	M10-МС-MBT12-	48.0	19.1	17.2	7.9	19	27
12	1/8	M12-МС-MBT2-	38.3	9.7	22.8	4.8	22	22
12	1/4	M12-МС-MBT4-	43.4	14.2	22.8	7.1	22	22
12	3/8	M12-МС-MBT6-	43.4	14.2	22.8	9.5	22	22
12	1/2	M12-МС-MBT8-	49.0	19.1	22.8	9.5	22	22
12	3/4	M12-МС-MBT12-	50.5	19.1	22.8	9.5	22	27
14	1/8	M14-МС-MBT2-	38.8	9.7	24.4	4.8	25	24
14	1/4	M14-МС-MBT4-	44.1	14.2	24.4	7.1	25	24
14	3/8	M14-МС-MBT6-	44.1	14.2	24.4	7.9	25	24
14	1/2	M14-МС-MBT8-	49.0	19.1	24.4	11.1	25	24
14	3/4	M14-МС-MBT12-	50.5	19.1	24.4	11.1	25	27
15	1/2	M15-МС-MBT8-	49.0	19.1	24.4	11.9	25	24
16	1/4	M16-МС-MBT4-	44.1	14.2	24.4	7.1	25	24
16	3/8	M16-МС-MBT6-	44.1	14.2	24.4	9.5	25	24
16	1/2	M16-МС-MBT8-	49.0	19.1	24.4	11.9	25	24
16	3/4	M16-МС-MBT12-	50.5	19.1	24.4	12.7	25	27
18	1/2	M18-МС-MBT8-	50.5	19.1	24.4	11.9	30	27
18	3/4	M18-МС-MBT12-	50.5	19.1	24.4	15.1	30	27
20	1/2	M20-МС-MBT8-	52.3	19.1	26.0	11.9	32	30
20	3/4	M20-МС-MBT12-	52.3	19.1	26.0	15.9	32	30
22	3/4	M22-МС-MBT12-	52.3	19.1	26.0	15.9	32	30
22	1	M22-МС-MBT16-	57.1	23.9	26.0	18.3	32	35
25	1/2	M25-МС-MBT8-	57.5	19.1	31.3	11.9	38	35
25	3/4	M25-МС-MBT12-	57.5	19.1	31.3	15.9	38	35
25	1	M25-МС-MBT16-	62.3	23.9	31.3	21.8	38	35
28	1	M28-МС-MBT16-	72.4	23.9	36.6	21.8	46	41
28	1 1/4	M28-МС-MBT20-	73.1	23.9	36.6	21.8	46	46
30	1 1/4	M30-МС-MBT20-	77.2	23.9	39.6	26.2	50	46
32	1 1/4	M32-МС-MBT20-	79.6	23.9	42.0	28.6	50	46
38	1 1/2	M38-МС-MBT24-	91.6	26.2	49.4	33.7	60	55

Штуцер с внешней резьбой

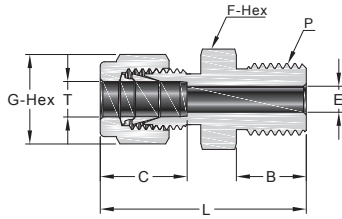

Дюймовая трубка

ISO Цилиндрическая резьба (BG)

Трубка, дюйм	P-BG Резьба	Артикул для заказа	Размеры, мм					
			L	B	C	E	G	F
1/4	3/8	F4-MC-MBP6-	38.4	14.2	15.2	4.8	14.3	17.5
3/8	3/8	F6-MC-MBP6-	39.9	14.2	16.8	7.1	17.5	17.5

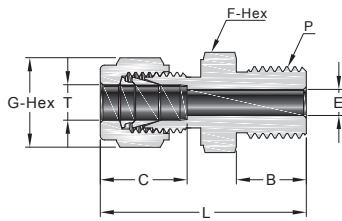

Метрическая трубка

ISO Цилиндрическая резьба (BG)

Трубка, мм	P-BG Резьба	Артикул для заказа	Размеры, мм					
			L	B	C	E	G	F
6	1/4	M6-MC-MBP4-	36.9	12.9	15.3	4.8	14	14
6	3/8	M6-MC-MBP6-	39.5	14.2	15.3	4.8	14	18
8	1/8	M8-MC-MBP2-	33.9	9.8	16.2	4.0	16	14
8	1/4	M8-MC-MBP4-	37.0	12.9	16.2	6.4	16	14
8	3/8	M8-MC-MBP6-	39.3	14.2	16.2	6.4	16	18
8	1/2	M8-MC-MBP8-	45.4	18.8	16.2	6.4	16	22
10	1/4	M10-MC-MBP4-	39.5	12.9	17.2	5.9	19	18
10	1/2	M10-MC-MBP8-	46.3	18.8	17.2	7.9	19	22
12	3/8	M12-MC-MBP6-	44.2	14.2	22.8	7.9	22	22
12	1/2	M12-MC-MBP8-	49.0	18.8	22.8	9.5	22	22
14	1/4	M14-MC-MBP4-	42.9	12.9	24.4	5.9	25	24
16	3/8	M16-MC-MBP6-	43.4	14.2	24.4	7.9	25	24
16	1/2	M16-MC-MBP8-	47.9	18.8	24.4	9.5	25	24
18	1/2	M18-MC-MBP8-	49.8	18.8	24.4	9.5	30	27

Штуцер с внешней резьбой

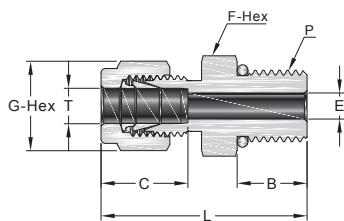

Адаптер по стандартам SAE J1926-1, ISO 11926-1 и MS 16142.

Дюймовая трубка

Прямая резьба SAE/MS с уплотнением

Трубка, дюйм	P-SAE/MS Размер резьбы	Артикул для заказа	Размеры, мм					
			L	B	C	E	G	F
1/16	5/16-24	F1-MC-OST5-	23.4	7.6	8.6	1.3	7.9	11.1
1/8	5/16-24	F2-MC-OST5-	30.0	7.6	12.7	2.3	11.1	11.1
1/8	7/16-20	F2-MC-OST7-	31.5	9.1	12.7	2.3	11.1	14.3
1/8	9/16-18	F2-MC-OST9-	33.3	9.9	12.7	2.3	11.1	17.5
3/16	3/8-24	F3-MC-OST6-	30.5	7.6	13.7	3.0	12.7	12.7
1/4	5/16-24	F4-MC-OST5-	32.3	7.6	15.2	2.3	14.3	12.7
1/4	7/16-20	F4-MC-OST7-	34.0	9.1	15.2	4.8	14.3	14.3
1/4	9/16-18	F4-MC-OST9-	35.6	9.9	15.2	4.8	14.3	17.5
1/4	3/4-16	F4-MC-OST12-	37.6	11.2	15.2	4.8	14.3	22.2
1/4	7/8-14	F4-MC-OST14-	40.6	12.7	15.2	4.8	15.9	25.4
5/16	1/2-20	F5-MC-OST8-	34.8	9.1	16.3	6.4	17.5	15.9
3/8	7/16-20	F6-MC-OST7-	35.6	9.1	16.8	5.1	17.5	15.9
3/8	9/16-18	F6-MC-OST9-	37.1	9.9	16.8	7.1	17.5	17.5
3/8	3/4-16	F6-MC-OST12-	39.1	11.2	16.8	7.1	17.5	22.2
3/8	7/8-14	F6-MC-OST14-	42.2	12.7	22.9	7.1	17.5	25.4
1/2	9/16-18	F8-MC-OST9-	39.1	9.9	22.9	7.1	22.2	20.6
1/2	3/4-16	F8-MC-OST12-	41.9	11.2	22.9	10.4	22.2	22.2
1/2	7/8-14	F8-MC-OST14-	45.0	12.7	22.9	10.4	22.2	25.4
1/2	1 1/16-12	F8-MC-OST17-	49.0	15.0	22.9	10.4	22.2	31.8
5/8	3/4-16	F10-MC-OST12-	41.9	11.2	24.4	10.7	25.4	23.8
5/8	7/8-14	F10-MC-OST14-	45.2	12.7	24.4	12.7	25.4	25.4
3/4	3/4-16	F12-MC-OST12-	46.0	11.2	24.4	10.7	28.6	27.0
3/4	1 1/16-12	F12-MC-OST17-	49.0	15.0	24.4	15.7	28.6	31.8
3/4	1 5/16-12	F12-MC-OST21-	49.8	15.0	24.4	16.0	28.6	38.1
7/8	1 3/16-12	F14-MC-OST19-	49.0	15.0	25.9	18.3	31.8	34.9
1	1 1/16-12	F16-MC-OST17-	53.3	15.0	31.2	16.8	38.1	34.9
1	1 5/16-12	F16-MC-OST21-	54.4	15.0	31.2	22.4	38.1	38.1
1 1/4	1 5/8-12	F20-MC-OST26-	68.3	15.0	41.1	27.7	47.6	47.6
1 1/2	1 7/8-12	F24-MC-OST30-	77.7	15.0	50.0	34.0	57.2	54.0

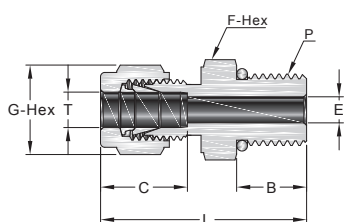

Адаптер по стандартам SAE J1926-1, ISO 11926-1 и MS 16142.

Метрическая трубка

Цилиндрическая резьба SAE/MS

Трубка, мм	P-SAE/MS Размер резьбы	Артикул для заказа	Размеры, мм					
			L	B	C	E	G	F
6	9/16-18	M6-MC-OST9-	35.6	9.9	15.3	4.8	14	18
10	9/16-18	M10-MC-OST9-	37.3	9.9	17.2	7.1	19	22
10	3/4-16	M10-MC-OST12-	39.4	11.2	17.2	7.9	19	22
12	7/16-20	M12-MC-OST7-	40.6	9.1	22.8	5.2	22	22
12	9/16-18	M12-MC-OST9-	39.9	9.9	22.8	7.1	22	22

Штуцер с внешней резьбой

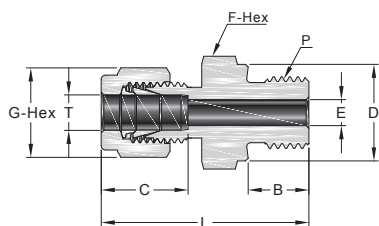

Дюймовая трубка

Цилиндрическая резьба ISO (BP)

Трубка, дюйм	P-ВР Резьба	Артикул для заказа	Размеры, мм						
			L	B	C	E	G	F	D
1/8	1/8	F2-MC-PMBP2-	30.0	7.1	12.7	2.3	11.1	14.3	13.7
1/8	1/4	F2-MC-PMBP4-	35.3	11.2	12.7	2.3	11.1	19.1	18.0
1/4	1/8	F4-MC-PMBP2-	32.3	7.1	15.2	4.1	14.3	14.3	13.8
1/4	1/4	F4-MC-PMBP4-	37.6	11.2	15.2	4.8	14.3	19.1	18.0
1/2	3/8	F8-MC-PMBP6-	40.4	11.2	22.9	7.9	22.2	22.2	21.8
1/2	1/2	F8-MC-PMBP8-	49.0	14.2	22.9	10.4	22.2	27.0	25.9
3/4	1/2	F12-MC-PMBP8-	49.0	14.2	24.4	11.9	28.6	27.0	25.9
3/4	3/4	F12-MC-PMBP12-	52.9	15.7	24.4	15.7	28.6	33.3	32
1	1	F16-MC-PMBP16-	59.9	18.3	31.2	19.8	38.1	41.3	39.1

Штуцер с внешней резьбой

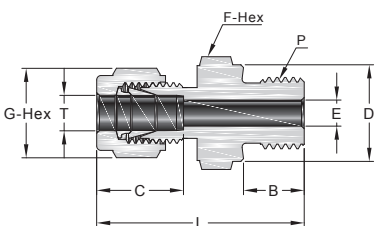

Метрическая трубка

Цилиндрическая резьба ISO (BP)

Трубка, мм	P-ВР Резьба	Артикул для заказа	Размеры, мм						
			L	B	C	E	G	F	D
3	1/8	M3-MC-PMBP2-	30.0	7.1	12.9	2.4	12	14	13.8
3	1/4	M3-MC-PMBP4-	35.3	11.2	12.9	2.4	12	19	18.0
4	1/8	M4-MC-PMBP2-	30.7	7.1	13.7	2.4	12	14	13.8
6	1/8	M6-MC-PMBP2-	32.3	7.1	15.3	4.0	14	14	13.8
6	1/4	M6-MC-PMBP4-	37.6	11.2	15.3	4.8	14	19	18.0
6	3/8	M6-MC-PMBP6-	38.9	11.2	15.3	4.8	14	22	21.8
6	1/2	M6-MC-PMBP8-	44.7	14.2	15.3	4.8	14	27	26.0
8	1/8	M8-MC-PMBP2-	33.3	7.1	16.2	4.0	16	15	13.8
8	1/4	M8-MC-PMBP4-	38.5	11.2	16.2	5.9	16	19	18.0
8	3/8	M8-MC-PMBP6-	39.8	11.2	16.2	6.4	16	22	21.8
8	1/2	M8-MC-PMBP8-	45.6	14.2	16.2	6.4	16	27	26.0
10	1/4	M10-MC-PMBP4-	39.4	11.2	17.2	5.9	19	19	18.0
10	3/8	M10-MC-PMBP6-	40.6	11.2	17.2	7.9	19	22	21.8
10	1/2	M10-MC-PMBP8-	46.5	14.2	17.2	7.9	19	27	26.0
12	1/4	M12-MC-PMBP4-	42.6	11.2	22.8	5.9	22	22	18.0
12	3/8	M12-MC-PMBP6-	43.1	11.2	22.8	7.9	22	22	21.8
12	1/2	M12-MC-PMBP8-	49.0	14.2	22.8	9.5	22	27	26.0
12	3/4	M12-MC-PMBP12-	52.8	15.7	22.8	9.5	22	35	32.0
15	1/2	M15-MC-PMBP8-	49.0	14.2	24.4	11.9	25	27	26.0
16	3/8	M16-MC-PMBP6-	43.9	11.2	24.4	7.9	25	24	21.8
16	1/2	M16-MC-PMBP8-	49.0	14.2	24.4	11.9	25	27	26.0
18	1/2	M18-MC-PMBP8-	49.0	14.2	24.4	11.9	30	27	26.0
18	3/4	M18-MC-PMBP12-	52.8	15.7	24.4	15.1	30	35	32.0
20	1/2	M20-MC-PMBP8-	50.5	14.2	26.0	11.9	32	30	26.0
20	3/4	M20-MC-PMBP12-	52.8	15.7	26.0	15.9	32	35	32.0
22	3/4	M22-MC-PMBP12-	52.8	15.7	26.0	15.9	32	35	32.0
22	1	M22-MC-PMBP16-	55.3	18.3	26.0	18.3	32	41	39.0
25	3/4	M25-MC-PMBP12-	57.5	15.7	31.3	15.9	38	35	32.0
25	1	M25-MC-PMBP16-	60.1	18.3	31.3	19.8	38	41	39.0
28	1	M28-MC-PMBP16-	70.1	18.3	36.6	19.8	46	41	39.0
28	1 1/4	M28-MC-PMBP20-	73.9	19.8	36.6	21.8	46	50	49.0
30	1 1/4	M30-MC-PMBP20-	76.5	19.8	39.6	26.2	50	50	49.0
32	1 1/4	M32-MC-PMBP20-	78.9	19.8	42.0	28.6	50	50	49.0
38	1 1/2	M38-MC-PMBP24-	89.3	20.6	49.4	31.8	60	55	54.7

Штуцер с внешней резьбой

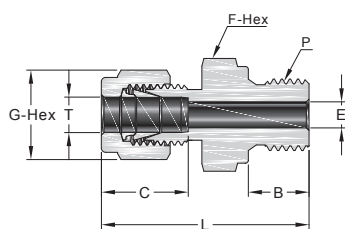

Дюймовая трубка

Цилиндрическая резьба ISO (BS)

Трубка, дюйм	P-BS Резьба	Артикул для заказа	Размеры, мм						
			L	B	C	E	G	F	D
1/8	1/8	F2-MC-MBS2-	30.0	7.1	12.7	2.3	11.1	14.3	13.7
1/8	1/4	F2-MC-MBS4-	35.3	11.2	12.7	2.3	11.1	19.1	18.0
1/8	3/8	F2-MC-MBS6-	36.3	11.2	12.7	2.3	11.1	22.2	21.8
1/4	1/8	F4-MC-MBS2-	32.3	7.1	15.2	4.0	14.3	14.3	13.7
1/4	1/4	F4-MC-MBS4-	37.6	11.2	15.2	4.8	14.3	19.1	18.0
1/4	3/8	F4-MC-MBS6-	38.9	11.2	15.2	4.8	14.3	22.2	21.8
1/4	1/2	F4-MC-MBS8-	44.7	14.2	15.2	4.8	14.3	27.0	25.9
3/8	1/8	F6-MC-MBS2-	37.8	7.1	16.8	4.0	17.5	15.9	13.7
3/8	1/4	F6-MC-MBS4-	39.1	11.2	16.8	5.9	17.5	19.1	18.0
3/8	3/8	F6-MC-MBS6-	40.4	11.2	16.8	7.1	17.5	22.2	21.8
3/8	1/2	F6-MC-MBS8-	46.2	14.2	16.8	7.1	17.5	27.0	25.9
1/2	1/4	F8-MC-MBS4-	42.7	11.2	22.9	5.9	22.2	20.6	18.0
1/2	3/8	F8-MC-MBS6-	43.2	11.2	22.9	7.9	22.2	22.2	21.8
1/2	1/2	F8-MC-MBS8-	49.0	14.2	22.9	10.4	22.2	27.0	25.9
3/4	1/2	F12-MC-MBS8-	49.0	14.2	24.4	11.9	28.6	27.0	25.9
3/4	3/4	F12-MC-MBS12-	52.9	15.7	24.4	15.7	28.6	33.3	32.0
1	1/2	F16-MC-MBS8-	55.5	14.2	31.2	11.9	38.1	34.9	25.9
1	3/4	F16-MC-MBS12-	57.7	15.7	31.2	16.0	38.1	34.9	32.0
1	1	F16-MC-MBS16-	59.9	18.3	31.2	19.8	38.1	41.3	39.1

Штуцер с внешней резьбой

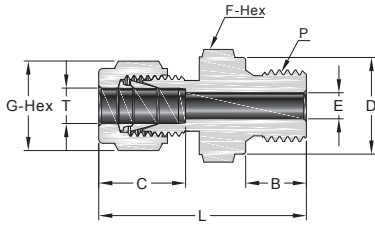

Метрическая трубка

Цилиндрическая резьба ISO (BS)

Трубка, мм	P-BS Резьба	Артикул для заказа	Размеры, мм						
			L	B	C	E	G	F	D
2	1/8	M2-MC-MBS2-	30.0	7.1	12.9	1.7	12	14	13.7
3	1/8	M3-MC-MBS2-	30.0	7.1	12.9	2.4	12	14	13.7
3	1/4	M3-MC-MBS4-	35.3	11.2	12.9	2.4	12	19	18.0
4	1/8	M4-MC-MBS2-	30.7	7.1	13.7	2.4	12	14	13.7
4	1/4	M4-MC-MBS4-	36.0	11.2	13.7	2.4	12	19	18.0
6	1/8	M6-MC-MBS2-	32.3	7.1	15.3	4.0	14	14	13.7
6	1/4	M6-MC-MBS4-	37.6	11.2	15.3	4.8	14	19	18.0
6	3/8	M6-MC-MBS6-	38.9	11.2	15.3	4.8	14	22	21.6
6	1/2	M6-MC-MBS8-	44.7	14.2	15.3	4.8	14	27	25.9
8	1/8	M8-MC-MBS2-	33.2	7.1	16.2	4.0	16	15	14.5
8	1/4	M8-MC-MBS4-	38.5	11.2	16.2	6.4	16	19	18.0
8	3/8	M8-MC-MBS6-	39.8	11.2	16.2	6.4	16	22	21.6
8	1/2	M8-MC-MBS8-	45.6	14.2	16.2	6.4	16	27	25.9
8	3/4	M8-MC-MBS12-	49.5	15.7	16.2	6.4	16	35	32.0
10	1/4	M10-MC-MBS4-	39.4	11.2	17.2	5.9	19	19	18.0
10	3/8	M10-MC-MBS6-	40.6	11.2	17.2	7.9	19	22	21.6
10	1/2	M10-MC-MBS8-	46.5	14.2	17.2	7.9	19	27	25.9
12	1/4	M12-MC-MBS4-	42.6	11.2	22.8	5.9	22	22	21.6
12	3/8	M12-MC-MBS6-	43.1	11.2	22.8	7.9	22	22	21.6
12	1/2	M12-MC-MBS8-	49.0	14.2	22.8	9.5	22	27	25.9
12	3/4	M12-MC-MBS12-	52.8	15.7	22.8	9.5	22	35	32.0
14	1/4	M14-MC-MBS4-	42.9	11.2	24.4	7.1	25	24	18.0
14	3/8	M14-MC-MBS6-	43.9	11.2	24.4	7.9	25	24	21.6
14	1/2	M14-MC-MBS8-	49.0	14.2	24.4	11.1	25	27	25.9
14	3/4	M14-MC-MBS12-	52.8	15.7	24.4	11.1	25	35	32.0
15	3/8	M15-MC-MBS6-	43.9	11.2	24.4	7.9	25	24	21.6
15	1/2	M15-MC-MBS8-	49.0	14.2	24.4	11.9	25	27	25.9
15	3/4	M15-MC-MBS12-	52.8	15.7	24.4	11.9	25	35	32.0
16	3/8	M16-MC-MBS6-	43.9	11.2	24.4	7.9	25	24	21.6
16	1/2	M16-MC-MBS8-	49.0	14.2	24.4	11.9	25	27	25.9
16	3/4	M16-MC-MBS12-	52.8	15.7	24.4	12.7	25	35	32.0
18	1/2	M18-MC-MBS8-	49.0	14.2	24.4	11.9	30	27	25.9
18	3/4	M18-MC-MBS12-	52.8	15.7	24.4	15.1	30	35	32.0
20	1/2	M20-MC-MBS8-	50.5	14.2	26.0	11.9	32	30	25.9
20	3/4	M20-MC-MBS12-	52.8	15.7	26.0	15.9	32	35	32.0
22	3/4	M22-MC-MBS12-	52.8	15.7	26.0	15.9	32	35	32.0
22	1	M22-MC-MBS16-	55.3	18.3	26.0	18.3	32	41	39.1
25	3/4	M25-MC-MBS12-	57.5	15.7	31.3	15.9	38	35	32.0
25	1	M25-MC-MBS16-	60.1	18.3	31.3	19.8	38	41	39.1
28	1	M28-MC-MBS16-	70.1	18.3	36.6	19.8	46	41	39.1
28	1 1/4	M28-MC-MBS20-	73.9	19.8	36.6	21.8	46	50	49.0
30	1 1/4	M30-MC-MBS20-	76.5	19.8	39.6	25.0	50	50	49.0
32	1 1/4	M32-MC-MBS20-	78.9	19.8	42.0	25.0	50	50	49.0
38	1 1/2	M38-MC-MBS24-	90.8	22.1	49.4	31.8	60	55	54.7

Штуцер с внешней резьбой

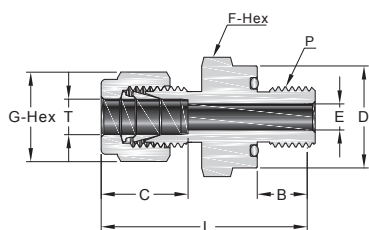

Дюймовая трубка

Прямая резьба SAE/MS с уплотнением

Трубка, дюйм	P-SAE/MS Размер резьбы	Артикул для заказа	Размеры, мм						
			L	B	C	E	G	F	D
1/16	5/16-24	F1-MC-STO5-	26.7	8.6	8.6	1.3	7.9	14.3	14.0
1/8	5/16-24	F2-MC-STO5-	32.8	8.6	12.7	2.3	11.1	14.3	14.0
3/16	3/8-24	F3-MC-STO6-	34.3	9.7	13.7	3.0	12.7	15.9	15.7
1/4	7/16-20	F4-MC-STO7-	38.4	10.4	15.2	4.8	14.3	19.1	18.8
5/16	1/2-20	F5-MC-STO8-	40.6	11.2	16.3	6.4	15.9	22.2	21.8
3/8	9/16-18	F6-MC-STO9-	42.4	11.9	16.8	7.1	17.5	23.8	23.6
1/2	3/4-16	F8-MC-STO12-	46.0	11.9	22.9	10.4	22.2	28.6	28.4
3/4	1 1/16-12	F12-MC-STO17-	52.3	14.2	24.4	15.7	28.6	38.1	37.8
1	1 5/16-12	F16-MC-STO21-	58.2	14.2	31.2	22.4	38.1	44.5	44.2

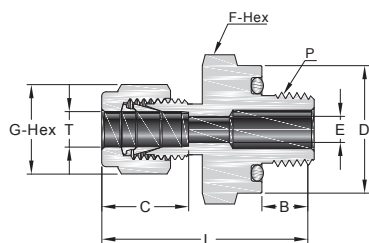

Дюймовая трубка

Резьба NPT с уплотнением

Трубка, дюйм	P-NPT Резьба	Артикул для заказа	Размеры, мм						
			L	B	C	E	G	F	D
1/8	1/8	F2-MC-NPT02-	32.8	7.1	8.6	2.3	11.1	19.1	18.8
1/4	1/8	F4-MC-NPT02-	35.1	7.1	15.2	4.8	14.3	19.1	18.8
1/4	1/4	F4-MC-NPT04-	38.4	9.7	15.2	4.8	14.3	23.8	23.6
3/8	1/4	F6-MC-NPT04-	39.9	9.7	16.8	7.1	17.5	23.8	23.6
3/8	3/8	F6-MC-NPT06-	41.4	10.4	16.8	7.1	17.5	28.6	28.4
3/8	1/2	F6-MC-NPT08-	47.0	13.5	16.8	7.1	17.5	33.3	33.0
1/2	1/2	F8-MC-NPT08-	49.8	13.5	22.9	10.4	22.2	33.3	33.0

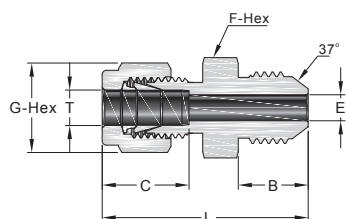

Дюймовая трубка

AN резьба 37°

Трубка, дюйм	Размер резьбы AN	Артикул для заказа	Размеры, мм					
			L	B	C	E	G	F
1/16	1/8	F1-MC-AN2-	1.07(27.2)	0.45(11.4)	0.34(8.6)	0.05(1.3)	0.31(7.9)	0.44(11.1)
1/8	1/8	F2-MC-AN2-	1.27(32.3)	0.45(11.4)	0.50(12.7)	0.06(1.5)	0.44(11.1)	0.44(11.1)
1/8	1/4	F2-MC-AN4-	1.38(35.1)	0.55(14.0)	0.50(12.7)	0.09(2.3)	0.44(11.1)	0.50(12.7)
3/16	3/16	F3-MC-AN3-	1.32(33.5)	0.48(12.2)	0.54(13.7)	0.09(2.3)	0.50(12.7)	0.44(11.1)
1/4	1/4	F4-MC-AN4-	1.48(37.6)	0.55(14.0)	0.60(15.2)	0.17(4.3)	0.56(14.3)	0.50(12.7)
5/16	5/16	F5-MC-AN5-	1.51(38.4)	0.55(14.0)	0.64(16.2)	0.23(5.8)	0.63(15.9)	0.56(14.3)
3/8	1/4	F6-MC-AN4-	1.56(39.6)	0.55(14.0)	0.66(16.8)	0.17(4.3)	0.69(17.5)	0.63(15.9)
3/8	3/8	F6-MC-AN6-	1.56(39.6)	0.56(14.1)	0.66(16.8)	0.28(7.1)	0.69(17.5)	0.63(15.9)
1/2	1/2	F8-MC-AN8-	1.81(46.0)	0.66(16.7)	0.90(22.8)	0.39(9.9)	0.87(22.2)	0.81(20.6)
5/8	5/8	F10-MC-AN10-	1.93(49.0)	0.76(19.3)	0.96(24.5)	0.48(12.3)	1.00(25.4)	0.94(23.8)
3/4	3/4	F12-MC-AN12-	2.10(53.3)	0.86(21.9)	0.96(24.4)	0.61(15.5)	1.13(28.6)	1.13(28.6)
	1	F16-MC-AN16-	2.42(61.5)	0.91(23.1)	1.23(31.2)	0.84(21.3)	1.50(38.1)	1.37(34.9)

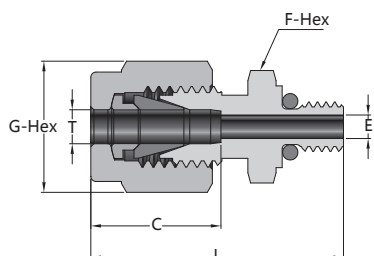

Дюймовая трубка

Резьба 10-32

Трубка, дюйм	Артикул для заказа	Размеры, мм				
		L	C	E	G	F
1/8	F2-MC-UNFD10	24.1	12.7	2.3	11.1	9.5
1/4	F4-MC-UNFD10	27.4	15.2	2.3	14.3	12.7

Штуцер с внешней резьбой

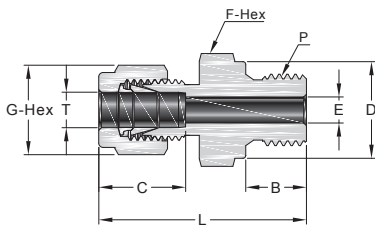

Дюймовая трубка

Метрическая резьба (BSMS)

Трубка, дюйм	Р-размер метрической резьбы	Артикул для заказа	Размеры, мм						
			L	B	C	E	G	F	D
1/8	M14x1.5	F2-MC-BSMS14-	36.7	12	12.7	2.3	11.1	19.1	19
1/8	M16x1.5	F2-MC-BSMS16-	37.5	12	12.7	2.3	11.1	22.2	21
1/8	M18x1.5	F2-MC-BSMS18-	38.5	12	12.7	2.3	11.1	23.8	23
1/8	M20x1.5	F2-MC-BSMS20-	41.1	14	12.7	2.3	11.1	25.4	25
1/4	M14x1.5	F4-MC-BSMS14-	38.0	12	15.2	4.8	14.3	19.1	19
1/4	M16x1.5	F4-MC-BSMS16-	39.9	12	15.2	4.8	14.3	22.2	21
1/4	M18x1.5	F4-MC-BSMS18-	40.8	12	15.2	4.8	14.3	23.8	23
1/4	M20x1.5	F4-MC-BSMS20-	43.6	14	15.2	4.8	14.3	25.4	25
3/8	M14x1.5	F6-MC-BSMS14-	41.3	12	16.8	7.1	17.5	19.1	19
3/8	M16x1.5	F6-MC-BSMS16-	41.3	12	16.8	7.1	17.5	22.2	21
3/8	M18x1.5	F6-MC-BSMS18-	41.8	12	16.8	7.1	17.5	23.8	23
3/8	M20x1.5	F6-MC-BSMS20-	45.1	14	16.8	7.1	17.5	25.4	25
1/2	M16x1.5	F8-MC-BSMS16-	44.0	12	22.9	9.0	22.2	22.2	21
1/2	M18x1.5	F8-MC-BSMS18-	44.0	12	22.9	10.0	22.2	23.8	23
1/2	M20x1.5	F8-MC-BSMS20-	47.9	14	22.9	10.4	22.2	25.4	25
1/2	M22x1.5	F8-MC-BSMS22-	48.5	14	22.9	10.4	22.2	27.0	27

Метрическая трубка

Метрическая резьба (BSMS)

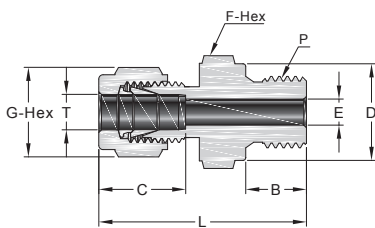

Трубка, мм	Р-размер метрической резьбы	Артикул для заказа	Размеры, мм						
			L	B	C	E	G	F	D
6	M8 x 1	M6-MC-BSMS8-	33.3	8	15.3	3.0	14	14	12
6	M10 x 1	M6-MC-BSMS10-	36.3	8	15.3	4.0	14	14	14
6	M12 x 1.5	M6-MC-BSMS12-	38.2	12	15.3	4.8	14	18	17
6	M14 x 1.5	M6-MC-BSMS14-	39.7	12	15.3	4.8	14	19	19
8	M8 x 1	M8-MC-BSMS8-	34.1	8	16.2	3.0	16	14	12
8	M10 x 1	M8-MC-BSMS10-	34.1	8	16.2	5.0	16	15	14
8	M12 x 1.5	M8-MC-BSMS12-	40.4	12	16.2	6.0	16	18	17
8	M14 x 1.5	M8-MC-BSMS14-	40.4	12	16.2	6.4	16	19	19
10	M12 x 1.5	M10-MC-BSMS12-	40.7	12	17.2	6.0	19	18	17
10	M14 x 1.5	M10-MC-BSMS14-	41.5	12	17.2	7.9	19	19	19
12	M16 x 1.5	M12-MC-BSMS16-	45.5	12	22.8	9	22	22	21
12	M20 x 1.5	M12-MC-BSMS20-	48.0	14	22.8	9.5	22	25	25
12	M22 x 1.5	M12-MC-BSMS22-	49.5	14	22.8	9.5	22	27	27
14	M14 x 1.5	M14-MC-BSMS14-	44.9	12	24.4	8	25	24	19
14	M20 x 1.5	M14-MC-BSMS20-	48.0	14	24.4	11.1	25	25	25
16	M20 x 1.5	M16-MC-BSMS20-	48.0	14	24.4	12	25	25	25
18	M20 x 1.5	M18-MC-BSMS20-	48.5	14	24.4	12	30	27	25
20	M20 x 1.5	M20-MC-BSMS20-	50.0	14	26.0	12	32	30	25
22	M24 x 1.5	M22-MC-BSMS24-	50.5	14	26.0	15	32	30	29
25	M27 x 2	M25-MC-BSMS27-	57.5	16	31.3	16.8	38	35	32

Штуцер с внешней резьбой

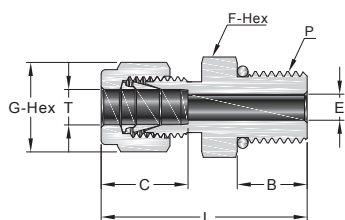

Adapt to straight thread boss of ISO 6149-1.

Дюймовая трубка

Метрическая резьба (OMS)

Трубка, дюйм	Р-размер метрической резьбы	Артикул для заказа	Размеры, мм					
			L	B	C	E	G	F
1/4	M14X1.5	F4-MC-OMS14-	35.2	11	15.2	4.8	14.3	19.1
3/8	M14X1.5	F6-MC-OMS14-	36.7	11	16.8	7.1	17.5	19.1
3/8	M20X1.5	F6-MC-OMS20-	41.2	14	16.8	7.1	17.5	27.0
1/2	M14X1.5	F8-MC-OMS14-	40.2	11	22.9	7.5	22.2	20.6
1/2	M20X1.5	F8-MC-OMS20-	44.0	14	22.9	10.4	22.2	27.0

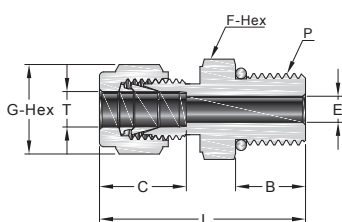

Адаптер по стандарту ISO 6149-1.

Метрическая трубка

Метрическая резьба (OMS)

Трубка, мм	Р-размер метрической резьбы	Артикул для заказа	Размеры, мм					
			L	B	C	E	G	F
6	M14 x 1.5	M6-MC-OMS14-	35.2	11	15.3	4.8	14	19
10	M14 x 1.5	M10-MC-OMS14-	36.7	11	17.2	7.5	19	19
10	M20 x 1.5	M10-MC-OMS20-	41.2	14	17.2	7.9	19	27
12	M14 x 1.5	M12-MC-OMS14-	40.2	11	22.8	7.5	22	22
12	M20 x 1.5	M12-MC-OMS20-	44.0	14	22.8	10.4	22	27

Дюймовая трубка

Метрическая резьба (MS)

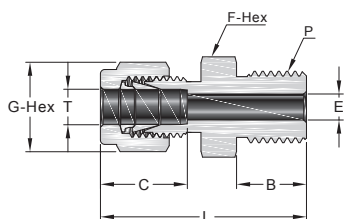

Трубка, дюйм	Р-размер метрической резьбы	Артикул для заказа	Размеры, мм					
			L	B	C	E	G	F
1/16	M5x0.8	F1-MC-MS5-	21.8	8	8.6	1.3	7.9	7.9
1/8	M14x1.5	F2-MC-MS14-	34.8	13	12.7	2.3	11.1	15.9
1/8	M16x1.5	F2-MC-MS16-	35.8	14	12.7	2.3	11.1	17.5
1/8	M18x1.5	F2-MC-MS18-	37.2	15	12.7	2.3	11.1	19.1
1/8	M20x1.5	F2-MC-MS20-	38.2	16	12.7	2.3	11.1	22.2
1/4	M14x1.5	F4-MC-MS14-	36.9	13	15.2	4.8	14.3	15.9
1/4	M16x1.5	F4-MC-MS16-	38.1	14	15.2	4.8	14.3	17.5
1/4	M18x1.5	F4-MC-MS18-	39.5	15	15.2	4.8	14.3	19.1
1/4	M20x1.5	F4-MC-MS20-	40.7	16	15.2	4.8	14.3	22.2
3/8	M10x1.0	F4-MC-MS10-	36.4	11	16.8	4.8	17.5	15.9
3/8	M14x1.5	F6-MC-MS14-	39.3	13	16.8	7.1	17.5	15.9
3/8	M16x1.5	F6-MC-MS16-	39.7	14	16.8	7.1	17.5	17.5
3/8	M18x1.5	F6-MC-MS18-	41.5	15	16.8	7.1	17.5	19.1
3/8	M20x1.5	F6-MC-MS20-	42.3	16	16.8	7.1	17.5	22.2
1/2	M16x1.5	F8-MC-MS16-	43.2	14	22.9	8.4	22.2	20.6
1/2	M18x1.5	F8-MC-MS18-	43.7	15	22.9	9.6	22.2	20.6
1/2	M20x1.5	F8-MC-MS20-	44.9	16	22.9	10.4	22.2	22.2
1/2	M22x1.5	F8-MC-MS22-	47.0	17	22.9	10.4	22.2	23.8

Штуцер с внешней резьбой

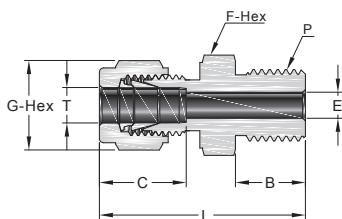

Метрическая трубка

Метрическая резьба (MS)

Трубка, дюйм	Р-размер метрической резьбы	Артикул для заказа	Размеры, мм					
			L	B	C	E	G	F
6	M6 x 1	M6-MC-MS6-	32.4	8	15.3	2.0	14	14
6	M8 x 1	M6-MC-MS8-	32.4	9	15.3	3.0	14	14
6	M10 x 1	M6-MC-MS10-	35.2	11	15.3	4.7	14	14
6	M12 x 1.5	M6-MC-MS12-	36.4	12	15.3	4.8	14	14
6	M14 x 1.5	M6-MC-MS14-	37.4	13	15.3	4.8	14	16
6	M16 x 1.5	M6-MC-MS16-	38.4	14	15.3	4.8	14	18
6	M18 x 1.5	M6-MC-MS18-	40.0	15	15.3	4.8	14	19
6	M20 x 1.5	M6-MC-MS20-	41.7	16	15.3	4.8	14	22
8	M8 x 1	M8-MC-MS8-	34.5	9	16.2	3.0	16	14
8	M10 x 1	M8-MC-MS10-	35.6	11	16.2	4.7	16	14
8	M12 x 1.5	M8-MC-MS12-	36.6	12	16.2	6.0	16	14
8	M14 x 1.5	M8-MC-MS14-	37.7	13	16.2	6.4	16	16
8	M20 x 1.5	M8-MC-MS20-	42.5	16	16.2	6.4	16	22
10	M12 x 1.5	M10-MC-MS12-	38.7	12	17.2	6.0	19	18
10	M14 x 1.5	M10-MC-MS14-	39.7	13	17.2	7.2	19	18
10	M20 x 1.5	M10-MC-MS20-	43.5	16	17.2	7.9	19	22
12	M12 x 1.5	M12-MC-MS12-	41.2	12	22.8	6.0	22	22
12	M16 x 1.5	M12-MC-MS16-	43.2	14	22.8	9.5	22	22
12	M18 x 1.5	M12-MC-MS18-	44.2	15	22.8	9.5	22	22
12	M20 x 1.5	M12-MC-MS20-	45.2	16	22.8	9.5	22	22
14	M14 x 1.5	M14-MC-MS14-	42.5	13	24.4	7.2	25	24
14	M16 x 1.5	M14-MC-MS16-	43.9	14	24.4	8.4	25	24
14	M20 x 1.5	M14-MC-MS20-	45.1	16	24.4	10.8	25	24
16	M20 x 1.5	M16-MC-MS20-	46.1	16	24.4	10.8	25	24
18	M20 x 1.5	M18-MC-MS20-	47.5	16	24.4	10.8	30	27
18	M22 x 1.5	M18-MC-MS22-	48.5	17	24.4	12	30	27
20	M20 x 1.5	M20-MC-MS20-	49.5	16	26.0	10.8	32	30
22	M24 x 1.5	M22-MC-MS24-	50.5	17	26.0	14.4	32	30
25	M27 x 2	M22-MC-MS27-	57.0	18	31.3	16.1	38	35

Фитинги с внешней резьбой для термопар

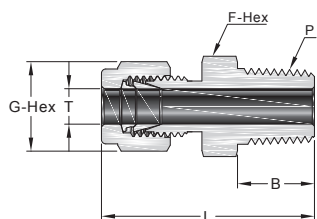

Дюймовая трубка

Резьба NPT

Трубка, дюйм	P-NPT резьба	Артикул для заказа	Размеры, мм			
			L	B	G	F
1/16	1/16	F1-TC-NPT1-	23.9	9.7	7.9	7.9
1/16	1/8	F1-TC-NPT2-	26.2	9.7	7.9	11.1
1/16	1/4	F1-TC-NPT4-	31.0	14.2	7.9	14.3
1/8	1/16	F2-TC-NPT1-	29.7	9.7	11.1	11.1
1/8	1/8	F2-TC-NPT2-	30.5	9.7	11.1	11.1
1/8	1/4	F2-TC-NPT4-	35.6	14.2	11.1	14.3
3/16	1/8	F3-TC-NPT2-	31.2	9.7	12.7	11.1
3/16	1/4	F3-TC-NPT4-	36.3	14.2	12.7	14.3
1/4	1/8	F4-TC-NPT2-	32.8	9.7	14.3	12.7
1/4	1/4	F4-TC-NPT4-	37.8	14.2	14.3	14.3
1/4	3/8	F4-TC-NPT6-	38.4	14.2	14.3	17.5
1/4	1/2	F4-TC-NPT8-	44.7	19.1	14.3	22.2
5/16	1/4	F5-TC-NPT4-	38.6	14.2	15.9	14.3
3/8	1/4	F6-TC-NPT4-	39.9	14.2	17.5	15.9
3/8	3/8	F6-TC-NPT6-	39.9	14.2	17.5	17.5
3/8	1/2	F6-TC-NPT8-	46.2	19.1	17.5	22.2
3/8	3/4	F6-TC-NPT12-	47.8	19.1	17.5	27.0
1/2	1/2	F8-TC-NPT8-	49.0	19.1	22.2	22.2
1/2	3/4	F8-TC-NPT12-	50.5	19.1	22.2	27.0
5/8	3/4	F10-TC-NPT12-	50.5	19.1	25.4	27.0
3/4	3/4	F12-TC-NPT12-	50.5	19.1	28.6	27.0
1	1	F16-TC-NPT16-	62.2	23.9	38.1	34.9

Фитинги с внешней резьбой для терморпар

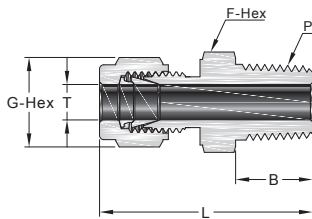

Метрическая трубка

Резьба NPT

Трубка, мм	P-NPT резьба	Артикул для заказа	Размеры, мм			
			L	B	G	F
2	1/8	M2-TC-NPT2-	30.5	9.7	12	12
3	1/8	M3-TC-NPT2-	30.5	9.7	12	12
3	1/4	M3-TC-NPT4-	35.6	14.2	12	14
4	1/8	M4-TC-NPT2-	31.2	9.7	12	12
4	1/4	M4-TC-NPT4-	36.3	14.2	12	14
6	1/8	M6-TC-NPT2-	32.8	9.7	14	14
6	1/4	M6-TC-NPT4-	37.9	14.2	14	14
6	3/8	M6-TC-NPT6-	38.4	14.2	14	18
6	1/2	M6-TC-NPT8-	44.7	19.1	14	22
8	1/4	M8-TC-NPT4-	38.7	14.2	16	15
8	3/8	M8-TC-NPT6-	39.3	14.2	16	18
8	1/2	M8-TC-NPT8-	45.6	19.1	16	22
10	3/8	M10-TC-NPT6-	40.9	14.2	19	18
10	1/2	M10-TC-NPT8-	46.5	19.1	19	22
10	3/4	M10-TC-NPT12-	48.0	19.1	19	27
10	1	M10-TC-NPT16-	54.6	23.9	19	35
12	3/8	M12-TC-NPT6-	43.4	14.2	22	22
12	1/2	M12-TC-NPT8-	49.0	19.1	22	22
12	3/4	M12-TC-NPT12-	50.5	19.1	22	27
14	1/2	M14-TC-NPT8-	49.0	19.1	25	24
14	3/4	M14-TC-NPT12-	50.5	19.1	25	27
15	1/2	M15-TC-NPT8-	49.0	19.1	25	24
15	3/4	M15-TC-NPT12-	50.5	19.1	25	27
15	1	M15-TC-NPT16-	57.1	23.9	25	35
16	3/4	M16-TC-NPT12-	50.5	19.1	25	27
18	3/4	M18-TC-NPT12-	50.5	19.1	30	27
20	1	M20-TC-NPT16-	57.1	23.9	32	35
22	1	M22-TC-NPT16-	57.1	23.9	32	35
25	1	M25-TC-NPT16-	62.3	23.9	38	35

Штуцер с внешней резьбой и монтажом на панель

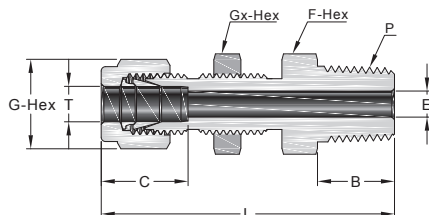

Дюймовая трубка

Резьба NPT

Трубка, дюйм	P-NPT резьба	Артикул для заказа	Размеры, мм							Диаметр отверстия в панели, мм	Макс. толщина панели, мм
			L	B	C	E	G	F	Gx		
1/16	1/16	F1-BMC-NPT1-	30.2	9.7	8.6	1.3	7.9	7.9	7.9	5.2	6.4
1/16	1/8	F1-BMC-NPT2-	32.3	9.7	8.6	1.3	7.9	11.1	7.9	5.2	6.4
1/8	1/8	F2-BMC-NPT2-	46.5	9.7	12.7	2.3	11.1	12.7	12.7	8.3	12.7
3/16	1/8	F3-BMC-NPT2-	48.0	9.7	13.7	3.0	12.7	14.3	14.3	9.9	12.7
1/4	1/8	F4-BMC-NPT2-	49.5	9.7	15.2	4.8	14.3	15.9	15.9	11.5	10.2
1/4	1/4	F4-BMC-NPT4-	54.1	14.2	15.2	4.8	14.3	15.9	15.9	11.5	10.2
1/4	3/8	F4-BMC-NPT6-	54.9	14.2	15.2	4.8	14.3	17.5	15.9	11.5	10.2
1/4	1/2	F4-BMC-NPT8-	60.3	19.1	15.2	4.8	14.3	22.2	15.9	11.5	10.2
5/16	1/8	F5-BMC-NPT2-	52.8	9.7	16.3	4.8	15.9	17.5	17.5	13.1	11.2
5/16	1/4	F5-BMC-NPT4-	57.7	14.2	16.3	6.4	15.9	17.5	17.5	13.1	11.2
3/8	1/8	F6-BMC-NPT2-	52.9	9.7	16.8	4.8	17.5	19.1	19.1	14.7	11.2
3/8	1/4	F6-BMC-NPT4-	57.4	14.2	16.8	7.1	17.5	19.1	19.1	14.7	11.2
3/8	3/8	F6-BMC-NPT6-	57.4	14.2	16.8	7.1	17.5	19.1	19.1	14.7	11.2
3/8	1/2	F6-BMC-NPT8-	63.8	19.1	16.8	7.1	17.5	22.2	19.1	14.7	11.2
1/2	1/8	F8-BMC-NPT2-	58.7	9.7	22.9	4.8	22.2	23.8	23.8	19.4	12.7
1/2	1/4	F8-BMC-NPT4-	63.2	14.2	22.9	7.1	22.2	23.8	23.8	19.4	12.7
1/2	3/8	F8-BMC-NPT6-	63.2	14.2	22.9	9.7	22.2	23.8	23.8	19.4	12.7
1/2	1/2	F8-BMC-NPT8-	68.8	19.1	22.9	10.4	22.2	23.8	23.8	19.4	12.7
5/8	3/8	F10-BMC-NPT6-	66.7	14.2	24.4	9.7	25.4	27.0	27.0	22.6	15.1
5/8	1/2	F10-BMC-NPT8-	71.5	19.1	24.4	11.9	25.4	27.0	27.0	22.6	15.1
3/4	1/2	F12-BMC-NPT8-	76.2	19.1	24.4	11.9	28.6	30.2	30.2	25.8	16.8
3/4	3/4	F12-BMC-NPT12-	76.2	19.1	24.4	15.7	28.6	30.2	30.2	25.8	16.8
7/8	3/4	F14-BMC-NPT12-	84.1	19.1	25.9	15.7	31.8	33.3	33.3	29.0	19.1
1	3/4	F16-BMC-NPT12-	88.4	19.1	31.2	15.7	38.1	41.3	41.3	33.7	19.1
1	1	F16-BMC-NPT16-	93.2	23.9	31.2	22.4	38.1	41.3	41.3	33.7	19.1

Метрическая трубка

Резьба NPT

Трубка, мм	P-NPT резьба	Артикул для заказа	Размеры, мм							Диаметр отверстия в панели, мм	Макс. толщина панели, мм
			L	B	C	E	G	F	Gx		
6	1/8	M6-BMC-NPT2-	49.6	9.7	15.3	4.8	14	16	16	11.5	10.2
6	1/4	M6-BMC-NPT4-	53.6	14.2	15.3	4.8	14	16	16	11.5	10.2
8	1/8	M8-BMC-NPT2-	52.3	9.7	16.2	4.8	16	18	18	13.1	11.2
8	1/4	M8-BMC-NPT4-	57.5	14.2	16.2	6.4	16	18	18	13.1	11.2
10	1/4	M10-BMC-NPT4-	58.4	14.2	17.2	7.9	19	22	22	16.3	11.2
10	3/8	M10-BMC-NPT6-	58.4	14.2	17.2	7.9	19	22	22	16.3	11.2
10	1/2	M10-BMC-NPT8-	63.1	19.1	17.2	7.9	19	22	22	16.3	11.2
12	1/4	M12-BMC-NPT4-	63.9	14.2	22.8	7.9	22	24	24	19.5	12.7
12	3/8	M12-BMC-NPT6-	63.9	14.2	22.8	9.5	22	24	24	19.5	12.7
12	1/2	M12-BMC-NPT8-	68.8	19.1	22.8	9.5	22	24	24	19.5	12.7

Штуцер с внешней резьбой и монтажом на панель

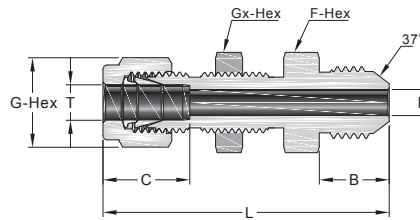

Дюймовая трубка

АН резьба 37°

Трубка, дюйм	Размер резьбы АН	Артикул для заказа	Размеры, дюйм (мм)							Диаметр отверстия в панели, мм	Макс. толщина панели, мм
			L	B	C	E	G	F	Gx		
1/8	1/8	F2-BMC-AN2-	1.91 (48.5)	0.45 (11.4)	0.50 (12.7)	0.06 (1.5)	0.44 (11.1)	0.50 (12.7)	0.50 (12.7)	0.33 (8.3)	0.50 (12.7)
1/8	1/4	F2-BMC-AN4-	2.04 (51.8)	0.55 (14.0)	0.50 (12.7)	0.09 (2.3)	0.44 (11.1)	0.63 (15.9)	0.50 (12.7)	0.33 (8.3)	0.51 (12.7)
3/16	3/16	F3-BMC-AN3-	1.98 (50.3)	0.48 (12.2)	0.54 (13.7)	0.09 (2.3)	0.50 (12.7)	0.56 (14.3)	0.56 (14.3)	0.39 (9.9)	0.50 (12.7)
1/4	1/4	F4-BMC-AN4-	2.12 (53.8)	0.55 (14.0)	0.60 (15.2)	0.17 (4.3)	0.56 (14.3)	0.63 (15.9)	0.63 (15.9)	0.45 (11.5)	0.40 (10.2)
5/16	5/16	F5-BMC-AN5-	2.21 (56.1)	0.55 (14.0)	0.64 (16.2)	0.23 (5.8)	0.63 (15.9)	0.69 (17.5)	0.69 (17.5)	0.52 (13.1)	0.56 (14.3)
3/8	1/4	F6-BMC-AN4-	2.25 (57.2)	0.55 (14.0)	0.66 (16.8)	0.17 (4.3)	0.69 (17.5)	0.75 (19.1)	0.75 (19.1)	0.58 (14.7)	0.44 (11.2)
3/8	3/8	F6-BMC-AN6-	2.25 (57.2)	0.56 (14.2)	0.66 (16.8)	0.28 (7.1)	0.69 (17.5)	0.75 (19.1)	0.75 (19.1)	0.58 (14.7)	0.44 (11.2)
1/2	1/2	F8-BMC-AN8-	2.59 (65.8)	0.66 (16.8)	0.90 (22.8)	0.39 (9.9)	0.87 (22.2)	0.94 (23.8)	0.94 (23.8)	0.76 (19.4)	0.50 (12.7)
5/8	5/8	F10-BMC-AN10-	2.74 (69.6)	0.76 (19.3)	0.96 (24.4)	0.48 (12.3)	1.00 (25.4)	1.06 (27.0)	1.06 (27.0)	0.89 (22.6)	0.59 (15.1)
3/4	3/4	F12-BMC-AN12-	3.11 (79.0)	0.86 (21.8)	0.96 (24.4)	0.61 (15.5)	1.13 (28.6)	1.19 (30.2)	1.19 (30.2)	1.02 (25.8)	0.66 (16.8)
1	1	F16-BMC-AN16-	3.64 (92.5)	0.91 (23.1)	1.23 (31.2)	0.84 (21.3)	1.50 (38.1)	1.63 (41.3)	1.63 (41.3)	1.33 (33.7)	0.75 (19.1)

Фитинг с внутренней резьбой

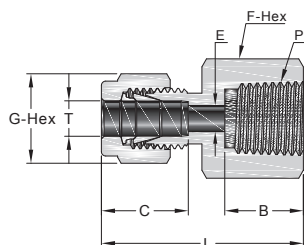

Дюймовая трубка

Резьба NPT

Трубка, дюйм	P-NPT резьба	Артикул для заказа	Размеры, мм					
			L	B	C	E	G	F
1/16	1/16	F1-FC-FNPT1-	23.6	9.9	8.6	1.3	7.9	11.1
1/16	1/8	F1-FC-FNPT2-	24.4	10.4	8.6	1.3	7.9	14.3
1/8	1/8	F2-FC-FNPT2-	28.7	10.4	12.7	2.3	11.1	14.3
1/8	1/4	F2-FC-FNPT4-	33.5	15.0	12.7	2.3	11.1	19.1
3/16	1/8	F3-FC-FNPT2-	29.7	10.4	13.7	3.0	12.7	14.3
1/4	1/8	F4-FC-FNPT2-	31.2	10.4	15.2	4.8	14.3	14.3
1/4	1/4	F4-FC-FNPT4-	35.8	15.0	15.2	4.8	14.3	19.1
1/4	3/8	F4-FC-FNPT6-	37.6	15.0	15.2	4.8	14.3	22.2
1/4	1/2	F4-FC-FNPT8-	42.4	19.8	15.2	4.8	14.3	27.0
5/16	1/8	F5-FC-FNPT2-	32.0	10.4	16.3	6.4	15.9	14.3
5/16	1/4	F5-FC-FNPT4-	36.8	15.0	16.3	6.4	15.9	19.1
3/8	1/8	F6-FC-FNPT2-	32.8	10.4	16.8	7.1	17.5	15.9
3/8	1/4	F6-FC-FNPT4-	37.6	15.0	16.8	7.1	17.5	19.1
3/8	3/8	F6-FC-FNPT6-	39.1	15.0	16.8	7.1	17.5	22.2
3/8	1/2	F6-FC-FNPT8-	43.9	19.8	16.8	7.1	17.5	27.0
3/8	3/4	F6-FC-FNPT12-	47.8	20.6	16.8	7.1	17.5	33.3
1/2	1/4	F8-FC-FNPT4-	40.4	15.0	22.9	10.4	22.2	20.6
1/2	3/8	F8-FC-FNPT6-	41.9	15.0	22.9	10.4	22.2	22.2
1/2	1/2	F8-FC-FNPT8-	46.7	19.8	22.9	10.4	22.2	27.0
1/2	3/4	F8-FC-FNPT12-	48.3	20.6	22.9	10.4	22.2	33.3
5/8	3/8	F10-FC-FNPT6-	41.9	15.0	24.4	12.7	25.4	23.8
5/8	1/2	F10-FC-FNPT8-	46.7	19.8	24.4	12.7	25.4	27.0
3/4	1/2	F12-FC-FNPT8-	46.7	19.8	24.4	15.7	28.6	27.0
3/4	3/4	F12-FC-FNPT12-	48.3	20.6	24.4	15.7	28.6	33.3
7/8	3/4	F14-FC-FNPT12-	49.8	20.6	25.9	18.3	31.8	33.3
1	3/4	F16-FC-FNPT12-	53.3	20.6	31.2	22.4	38.1	34.9
1	1	F16-FC-FNPT16-	62.2	25.4	31.2	22.4	38.1	41.3
1 1/4	1 1/4	F20-FC-FNPT20-	74.7	25.4	41.1	27.7	47.6	54.0
1 1/2	1 1/2	F24-FC-FNPT24-	83.3	27.7	50.0	36.3	57.2	60.3

Фитинг с внутренней резьбой

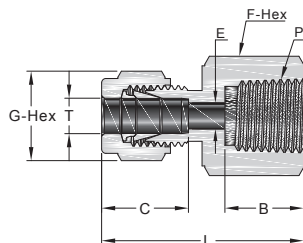

Метрическая трубка

Резьба NPT

Трубка, мм	P-NPT резьба	Артикул для заказа	Размеры, мм					
			L	B	C	E	G	F
3	1/8	M3-FC-FNPT2-	28.7	10.4	12.9	2.4	12	14
3	1/4	M3-FC-FNPT4-	33.5	15.0	12.9	2.4	12	19
4	1/8	M4-FC-FNPT2-	29.7	10.4	13.7	2.4	12	14
6	1/8	M6-FC-FNPT2-	31.3	10.4	15.3	4.8	14	14
6	1/4	M6-FC-FNPT4-	35.8	15.0	15.3	4.8	14	19
6	3/8	M6-FC-FNPT6-	37.7	15.0	15.3	4.8	14	22
6	1/2	M6-FC-FNPT8-	42.5	19.8	15.3	4.8	14	27
8	1/8	M8-FC-FNPT2-	32.1	10.4	16.2	6.4	16	15
8	1/4	M8-FC-FNPT4-	37.0	15.0	16.2	6.4	16	19
8	3/8	M8-FC-FNPT6-	38.5	15.0	16.2	6.4	16	22
8	1/2	M8-FC-FNPT8-	43.3	19.8	16.2	6.4	16	27
10	1/8	M10-FC-FNPT2-	33.0	10.4	17.2	6.4	19	18
10	1/4	M10-FC-FNPT4-	37.8	15.0	17.2	7.9	19	19
10	3/8	M10-FC-FNPT6-	39.4	15.0	17.2	7.9	19	22
10	1/2	M10-FC-FNPT8-	44.2	19.8	17.2	7.9	19	27
12	1/4	M12-FC-FNPT4-	40.3	15.0	22.8	7.9	22	22
12	3/8	M12-FC-FNPT6-	41.9	15.0	22.8	9.5	22	22
12	1/2	M12-FC-FNPT8-	46.7	19.8	22.8	9.5	22	27
12	3/4	M12-FC-FNPT12-	49.7	20.6	22.8	9.5	22	35
14	3/4	M14-FC-FNPT12-	49.7	20.6	24.4	11.1	25	35
15	1/2	M15-FC-FNPT8-	46.7	19.8	24.4	11.9	25	27
16	3/8	M16-FC-FNPT6-	41.9	15.0	24.4	9.5	25	27
16	1/2	M16-FC-FNPT8-	46.9	19.8	24.4	11.9	25	27
20	1/2	M20-FC-FNPT8-	47.9	19.8	26.0	11.9	32	30
20	3/4	M20-FC-FNPT12-	49.7	20.6	26.0	15.9	32	35
22	3/4	M22-FC-FNPT12-	49.7	20.6	26.0	15.9	32	35
22	1	M22-FC-FNPT16-	57.9	25.4	26.0	18.3	32	41
25	3/4	M25-FC-FNPT12-	53.4	20.6	31.3	15.9	38	35
25	1	M25-FC-FNPT16-	62.3	25.4	31.3	21.8	38	41

Фитинг с внутренней резьбой

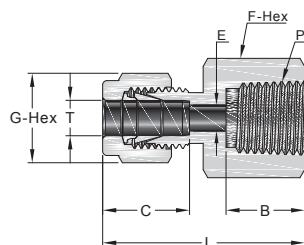

Дюймовая трубка

Коническая резьба ISO (BSPT)

Трубка, дюйм	P-BSPT Резьба	Артикул для заказа	Размеры, мм					
			L	B	C	E	G	F
1/4	1/8	F4-FC-FBT2-	31.2	10.4	15.2	4.8	14.3	14.3
1/4	1/4	F4-FC-FBT4-	35.8	15.0	15.2	4.8	14.3	19.1
1/4	3/8	F4-FC-FBT6-	37.6	15.0	15.2	4.8	14.3	22.2
1/4	1/2	F4-FC-FBT8-	42.4	19.8	15.2	4.8	14.3	27.0
3/8	1/4	F6-FC-FBT4-	37.6	15.0	16.8	7.1	17.5	19.1
3/8	3/8	F6-FC-FBT6-	39.1	15.0	16.8	7.1	17.5	22.2
3/8	1/2	F6-FC-FBT8-	43.9	19.8	16.8	7.1	17.5	27.0
1/2	1/4	F8-FC-FBT4-	40.4	15.0	22.9	10.4	22.2	20.6
1/2	3/8	F8-FC-FBT6-	41.9	15.0	22.9	10.4	22.2	22.2
1/2	1/2	F8-FC-FBT8-	46.7	19.8	22.9	10.4	22.2	27.0

Метрическая трубка

Коническая резьба ISO (BSPT)

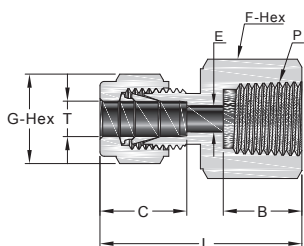

Трубка, мм	P-BSPT Резьба	Артикул для заказа	Размеры, мм					
			L	B	C	E	G	F
3	1/8	M3-FC-FBT2-	28.7	10.4	12.9	2.4	12	14
6	1/8	M6-FC-FBT2-	31.3	10.4	15.3	4.8	14	14
6	1/4	M6-FC-FBT4-	35.8	15.0	15.3	4.8	14	19
6	3/8	M6-FC-FBT6-	36.9	15.0	15.3	4.8	14	22
6	1/2	M6-FC-FBT8-	42.5	19.8	15.3	4.8	14	27
8	1/8	M8-FC-FBT2-	32.1	10.4	16.2	6.4	16	15
8	1/4	M8-FC-FBT4-	37.0	15.0	16.2	6.4	16	19
8	3/8	M8-FC-FBT6-	38.5	15.0	16.2	6.4	16	22
8	1/2	M8-FC-FBT8-	43.3	19.8	16.2	6.4	16	27
10	1/8	M10-FC-FBT2-	33.0	10.4	17.2	7.9	19	18
10	1/4	M10-FC-FBT4-	37.8	15.0	17.2	7.9	19	19
10	3/8	M10-FC-FBT6-	39.4	15.0	17.2	7.9	19	22
10	1/2	M10-FC-FBT8-	44.2	19.8	17.2	7.9	19	27
12	1/8	M12-FC-FBT2-	35.5	10.4	22.8	8.3	22	22
12	1/4	M12-FC-FBT4-	40.3	15.0	22.8	9.5	22	22
12	3/8	M12-FC-FBT6-	41.9	15.0	22.8	9.5	22	22
12	1/2	M12-FC-FBT8-	46.7	19.8	22.8	9.5	22	27
12	3/4	M12-FC-FBT12-	49.0	20.6	22.8	9.5	22	35
15	1/2	M15-FC-FBT8-	46.7	19.8	24.4	11.9	25	27
16	1/2	M16-FC-FBT8-	48.4	19.8	24.4	11.9	25	27
16	3/4	M16-FC-FBT12-	49.7	20.6	24.4	12.7	25	35
20	1/2	M20-FC-FBT8-	47.9	19.8	26.0	11.9	32	30
20	3/4	M20-FC-FBT12-	49.7	20.6	26.0	15.9	32	35
22	3/4	M22-FC-FBT12-	49.7	20.6	26.0	15.9	32	35
22	1	M22-FC-FBT16-	57.9	25.4	26.0	18.3	32	41
25	3/4	M25-FC-FBT12-	53.4	20.6	31.3	15.9	38	35
25	1	M25-FC-FBT16-	62.3	25.4	31.3	21.8	38	41

Фитинг с внутренней резьбой

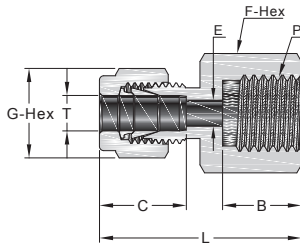

Дюймовая трубка

Цилиндрическая резьба ISO (BG)

Трубка, дюйм	P-BG Резьба	Артикул для заказа	Размеры, мм					
			L	B	C	E	G	F
1/8	1/4	F2-FC-FBP4-	35.3	12.9	12.7	2.3	11.1	19.1
1/8	3/8	F2-FC-FBP6-	38.7	14.2	12.7	2.3	11.1	23.8
1/4	1/4	F4-FC-FBP4-	37.6	12.9	15.2	4.8	14.3	19.1
1/4	3/8	F4-FC-FBP6-	37.6	14.2	15.2	4.8	14.3	23.8
1/4	1/2	F4-FC-FBP8-	43.4	18.8	15.2	4.8	14.3	27.0
5/16	1/4	F5-FC-FBP4-	38.4	12.9	16.3	5.6	15.9	19.1
5/16	3/8	F5-FC-FBP6-	39.2	14.2	16.3	6.4	15.9	23.8
5/16	1/2	F5-FC-FBP8-	40.9	18.8	16.3	7.1	15.9	27.0
3/8	1/4	F6-FC-FBP4-	39.1	12.9	16.8	5.6	17.5	19.1
3/8	3/8	F6-FC-FBP6-	38.6	14.2	16.8	6.4	17.5	23.8
3/8	1/2	F6-FC-FBP8-	41.9	18.8	16.8	7.1	17.5	27.0
1/2	1/4	F8-FC-FBP4-	41.9	12.9	22.9	5.6	22.2	22.2
1/2	3/8	F8-FC-FBP6-	44.5	14.2	22.9	6.4	22.2	23.8
1/2	1/2	F8-FC-FBP8-	48.3	18.8	22.9	7.1	22.2	27.0

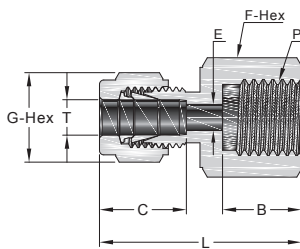

Метрическая трубка

Цилиндрическая резьба ISO (BG)

Трубка, мм	P-BG Резьба	Артикул для заказа	Размеры, мм					
			L	B	C	E	G	F
3	1/4	M3-FC-FBP4-	35.3	12.9	12.9	2.4	12	19
6	1/4	M6-FC-FBP4-	37.6	12.9	15.3	4.8	14	19
6	3/8	M6-FC-FBP6-	37.6	14.2	15.3	4.8	14	24
6	1/2	M6-FC-FBP8-	43.5	18.8	15.3	4.8	14	27
8	1/4	M8-FC-FBP4-	38.5	12.9	16.2	6.4	16	19
8	3/8	M8-FC-FBP6-	36.2	14.2	16.2	6.4	16	24
8	1/2	M8-FC-FBP8-	41.0	18.8	16.2	6.4	16	27
10	1/4	M10-FC-FBP4-	39.4	12.9	17.2	5.9	19	19
10	3/8	M10-FC-FBP6-	38.8	14.2	17.2	7.9	19	24
10	1/2	M10-FC-FBP8-	42.1	18.8	17.2	7.9	19	27
12	1/4	M12-FC-FBP4-	41.9	12.9	22.8	5.9	22	22
12	3/8	M12-FC-FBP6-	44.4	14.2	22.8	7.9	22	24
12	1/2	M12-FC-FBP8-	48.2	18.8	22.8	9.5	22	27
20	1/2	M20-FC-FBP8-	54.3	18.8	26.0	11.9	32	30
22	1/2	M22-FC-FBP8-	54.3	18.8	26.0	11.9	32	30

Фитинг с внутренней резьбой

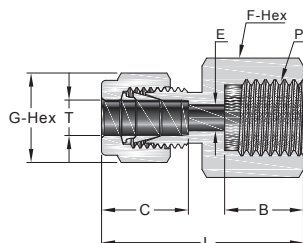

Дюймовая трубка

Метрическая резьба

Трубка, дюйм	Р-размер метрической резьбы	Артикул для заказа	Размеры, мм					
			L	B	C	E	G	F
1/8	M14 x 1.5	F2-FC-FMS14-	32.3	13	12.7	2.3	11.1	19.1
1/8	M16 x 1.5	F2-FC-FMS16-	33.3	14	12.7	2.3	11.1	22.2
1/8	M18 x 1.5	F2-FC-FMS18-	34.3	15	12.7	2.3	11.1	25.4
1/8	M20 x 1.5	F2-FC-FMS20-	35.3	16	12.7	2.3	11.1	27.0
1/4	M16 x 1.5	F4-FC-FMS16-	35.8	14	15.2	4.8	14.3	22.2
1/4	M18 x 1.5	F4-FC-FMS18-	36.8	15	15.2	4.8	14.3	25.4
1/4	M20 x 1.5	F4-FC-FMS20-	37.8	16	15.2	4.8	14.3	27.0
3/8	M14 x 1.5	F6-FC-FMS14-	37.1	13	16.8	7.1	17.5	19.1
3/8	M16 x 1.5	F6-FC-FMS16-	37.5	14	16.8	7.1	17.5	22.2
3/8	M18 x 1.5	F6-FC-FMS18-	38.5	15	16.8	7.1	17.5	25.4
3/8	M20 x 1.5	F6-FC-FMS20-	39.5	16	16.8	7.1	17.5	27.0
1/2	M16 x 1.5	F8-FC-FMS16-	41.4	14	22.9	8.4	22.2	22.2
1/2	M18 x 1.5	F8-FC-FMS18-	42.4	15	22.9	9.6	22.2	25.4
1/2	M20 x 1.5	F8-FC-FMS20-	43.4	16	22.9	10.4	22.2	27.0
1/2	M22 x 1.5	F8-FC-FMS22-	44.4	17	22.9	10.4	22.2	27.0

Метрическая трубка

Метрическая резьба

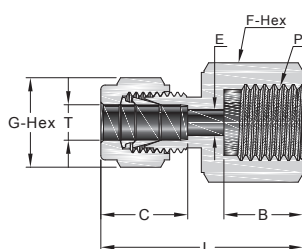

Трубка, дюйм	Р-размер метрической резьбы	Артикул для заказа	Размеры, мм					
			L	B	C	E	G	F
6	M10 x 1	M6-FC-FMS10-	32.7	11	15.3	4.0	14	16
6	M14 x 1.5	M6-FC-FMS14-	34.7	13	15.3	4.8	14	19
6	M20 x 1.5	M6-FC-FMS20-	37.7	16	15.3	4.8	14	27
8	M8 x 1	M8-FC-FMS8-	31.6	9	16.2	3.2	16	14
8	M10 x 1	M8-FC-FMS10-	33.6	11	16.2	4.0	16	16
8	M14 x 1.5	M8-FC-FMS14-	35.6	13	16.2	6.0	16	19
8	M20 x 1.5	M8-FC-FMS20-	38.6	16	16.2	6.4	16	27
10	M16 x 1.5	M10-FC-FMS16-	38.1	14	17.2	7.9	19	22
12	M20 x 1.5	M12-FC-FMS20-	44.9	16	22.8	9.5	22	27
14	M10 x 1	M14-FC-FMS10-	42.5	11	24.4	4.0	25	24
14	M20 x 1.5	M14-FC-FMS20-	44.9	16	24.4	10.8	25	27
14	M22 x 1.5	M14-FC-FMS22-	45.9	17	24.4	11.1	25	27
16	M20 x 1.5	M16-FC-FMS20-	44.9	16	24.4	10.8	26	27
20	M20 x 1.5	M20-FC-FMS20-	46.5	16	26.0	10.8	32	30
25	M27 x 2	M25-FC-FMS27-	54.4	18	31.3	16.1	38	35

Штуцер с внутренней резьбой и монтажом на панель

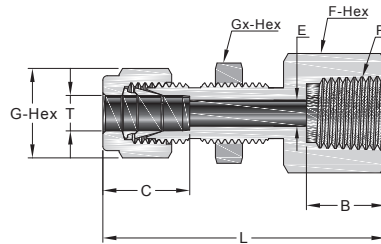

Дюймовая трубка

Резьба NPT

Трубка, дюйм	P-NPT Резьба	Артикул для заказа	Размеры, мм							Диаметр отверстия в панели, мм	Макс. толщина панели, мм
			L	B	C	E	G	F	Gx		
1/16	1/16	F1-BFC-FNPT1-	26.2	9.9	8.6	1.3	7.9	11.1	7.9	5.2	3.2
1/16	1/8	F1-BFC-FNPT2-	26.9	10.4	8.6	1.3	7.9	14.3	7.9	5.2	3.2
1/8	1/8	F2-BFC-FNPT2-	44.7	10.4	12.7	2.3	11.1	14.3	12.7	8.3	12.7
1/8	1/4	F2-BFC-FNPT4-	49.6	15.0	12.7	2.3	11.1	19.1	12.7	8.3	12.7
3/16	1/8	F3-BFC-FNPT2-	45.5	10.4	13.7	3.0	12.7	14.3	14.3	9.9	12.7
1/4	1/8	F4-BFC-FNPT2-	47.0	10.4	15.2	4.8	14.3	15.9	15.9	11.5	10.2
1/4	1/4	F4-BFC-FNPT4-	51.8	15.0	15.2	4.8	14.3	19.1	15.9	11.5	10.2
1/4	3/8	F4-BFC-FNPT6-	53.3	15.0	15.2	4.8	14.3	22.2	15.9	11.5	10.2
1/4	1/2	F4-BFC-FNPT8-	58.2	19.8	15.2	4.8	14.3	27.0	15.9	11.5	10.2
5/16	1/8	F5-BFC-FNPT2-	49.8	10.4	16.3	6.4	15.9	14.3	17.5	13.1	11.2
5/16	1/4	F5-BFC-FNPT4-	60.5	15.0	16.3	6.4	15.9	19.1	17.5	13.1	11.2
3/8	1/8	F6-BFC-FNPT2-	50.3	10.4	16.8	7.1	17.5	15.9	19.1	14.5	11.2
3/8	1/4	F6-BFC-FNPT4-	55.1	15.0	16.8	7.1	17.5	19.1	19.1	14.5	11.2
3/8	3/8	F6-BFC-FNPT6-	56.6	15.0	16.8	7.1	17.5	22.2	19.1	14.5	11.2
3/8	1/2	F6-BFC-FNPT8-	61.5	19.8	16.8	7.1	17.5	27.0	19.1	14.5	11.2
3/8	3/4	F6-BFC-FNPT12-	65.3	20.6	16.8	7.1	17.5	33.3	19.1	14.5	11.2
1/2	1/4	F8-BFC-FNPT4-	60.2	15.0	22.9	10.4	22.2	23.8	23.8	19.4	12.7
1/2	3/8	F8-BFC-FNPT6-	61.7	15.0	22.9	10.4	22.2	23.8	23.8	19.4	12.7
1/2	1/2	F8-BFC-FNPT8-	66.5	19.8	22.9	10.4	22.2	27.0	23.8	19.4	12.7
1/2	3/4	F8-BFC-FNPT12-	68.1	20.6	22.9	10.4	22.2	33.3	23.8	19.4	12.7
5/8	3/8	F10-BFC-FNPT6-	62.5	15.0	24.4	12.7	25.4	23.8	27.0	22.6	15.1
5/8	1/2	F10-BFC-FNPT8-	67.3	19.8	24.4	12.7	25.4	27.0	27.0	22.6	15.1
3/4	1/2	F12-BFC-FNPT8-	72.2	19.8	24.4	15.7	28.6	27.0	30.2	25.8	19.8
3/4	3/4	F12-BFC-FNPT12-	73.7	20.6	24.4	15.7	28.6	33.3	30.2	25.8	19.8
7/8	3/4	F14-BFC-FNPT12-	80.8	20.6	25.9	18.3	31.8	33.3	33.3	29.0	23.8
1	3/4	F16-BFC-FNPT12-	84.7	20.6	31.2	22.4	38.1	41.3	41.3	33.7	23.8
1	1	F16-BFC-FNPT16-	93.5	25.4	31.2	22.4	38.1	41.3	41.3	33.7	23.8

Метрическая трубка

Резьба NPT

Трубка, мм	P-NPT Резьба	Артикул для заказа	Размеры, мм							Диаметр отверстия в панели, мм	Макс. толщина панели, мм
			L	B	C	E	G	F	Gx		
6	1/8	M6-BFC-FNPT2-	47.2	10.4	15.3	4.8	14	16	16	11.5	10.2
6	1/4	M6-BFC-FNPT4-	51.8	15.0	15.3	4.8	14	19	16	11.5	10.2
8	1/8	M8-BFC-FNPT2-	49.6	10.4	16.2	4.8	16	18	18	13.1	11.2
10	1/4	M10-BFC-FNPT4-	55.2	15.0	17.2	7.9	19	22	22	16.3	11.2
12	3/8	M12-BFC-FNPT6-	60.9	15.0	22.8	9.5	22	24	24	19.5	12.7
12	1/2	M12-BFC-FNPT8-	66.5	19.8	22.8	9.5	22	27	24	19.5	12.7

Муфты

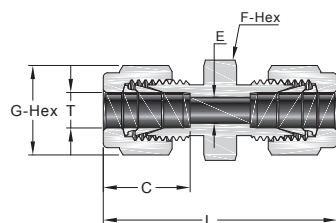

Дюймовая трубка

Трубка, дюйм	Артикул для заказа	Размеры, мм				
		L	C	G	F	E
1/16	F1-U-F1-	25.1	8.6	7.9	11.1	1.3
1/8	F2-U-F2-	35.6	12.7	11.1	11.1	2.3
3/16	F3-U-F3-	37.3	13.7	12.7	12.7	3.0
1/4	F4-U-F4-	40.9	15.2	14.3	12.7	4.8
5/16	F5-U-F5-	42.9	16.2	15.9	14.3	6.4
3/8	F6-U-F6-	45.0	16.8	17.5	15.9	7.1
1/2	F8-U-F8-	51.3	22.9	22.2	20.6	10.4
5/8	F10-U-F10-	52.1	24.4	25.4	23.9	12.7
3/4	F12-U-F12-	53.6	24.4	28.6	27.0	15.7
7/8	F14-U-F14-	55.1	25.9	31.8	34.9	18.3
1	F16-U-F16-	64.8	31.2	38.1	34.9	22.4
1 1/8	F18-U-F18-	64.8	31.2	44.5	41.3	24.6
1 1/4	F20-U-F20-	92.2	41.1	47.6	44.5	27.7
1 1/2	F24-U-F24-	108	50.0	57.2	54.0	34.0

Метрическая трубка

Трубка, мм	Артикул для заказа	Размеры, мм				
		L	C	G	F	E
2	M2-U-M2-	35.6	12.9	12	12	1.7
3	M3-U-M3-	35.3	12.9	12	12	2.4
4	M4-U-M4-	37.3	13.7	12	12	2.4
6	M6-U-M6-	41.0	15.3	14	14	4.8
8	M8-U-M8-	43.2	16.2	16	15	6.4
10	M10-U-M10-	46.2	17.2	19	18	7.9
12	M12-U-M12-	51.2	22.8	22	22	9.5
14	M14-U-M14-	52.0	24.4	25	24	11.1
15	M15-U-M15-	52.0	24.4	25	24	11.9
16	M16-U-M16-	52.0	24.4	25	24	12.7
18	M18-U-M18-	53.5	24.4	30	27	15.1
20	M20-U-M20-	55.0	26.0	32	30	15.9
22	M22-U-M22-	55.0	26.0	32	30	18.3
25	M25-U-M25-	65.0	31.3	38	35	21.8
28	M28-U-M28-	85.0	36.6	46	41	21.8
30	M30-U-M30-	92.7	39.6	50	46	26.2
32	M32-U-M32-	97.3	42.0	50	46	28.6
38	M38-U-M38-	113.6	49.4	60	55	33.7

Переходные муфты

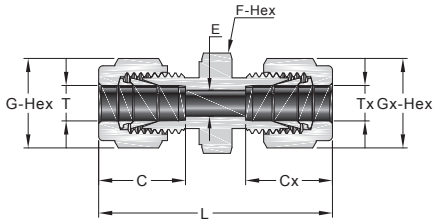

Метрическая трубка

Дюймовая трубка

Трубка, мм	Трубка, дюйм	Артикул для заказа	Размеры, мм						
			L	C	G	F	E	Cx	Gx
3	1/8	M3-U-F2-	35.2	12.9	12	12	2.4	12.7	11.1
4	1/8	M4-U-F2-	36.5	13.7	12	12	2.4	12.7	11.1
4	1/4	M4-U-F4-	39.4	13.7	12	14	2.4	15.2	14.3
6	1/8	M6-U-F2-	38.5	15.3	14	14	2.4	12.7	11.1
6	1/4	M6-U-F4-	41.0	15.3	14	14	4.8	15.2	14.3
6	5/16	M6-U-F5-	42.3	15.3	14	14	4.8	16.2	15.9
8	1/4	M8-U-F4-	42.3	16.2	16	15	4.8	15.2	14.3
8	3/8	M8-U-F6-	44.3	16.2	16	16	6.4	16.8	17.5
10	1/8	M10-U-F2-	41.8	17.2	19	18	2.4	12.7	11.1
10	1/4	M10-U-F4-	44.5	17.2	19	18	4.8	15.2	14.3
10	5/16	M10-U-F5-	45.1	17.2	19	18	6.4	16.2	15.9
10	3/8	M10-U-F6-	45.9	17.2	19	18	7.1	16.8	17.5
12	5/16	M12-U-F5-	47.8	22.8	22	22	6.4	16.2	15.9
12	3/8	M12-U-F6-	48.4	22.8	22	22	7.1	16.8	17.5
12	1/2	M12-U-F8-	51.2	22.8	22	22	9.5	22.9	22.2
15	1/2	M15-U-F8-	52.0	24.4	25	24	10.4	22.9	22.2
16	5/8	M16-U-F10-	52.0	24.4	25	24	12.7	24.4	25.4
18	3/4	M18-U-F12-	53.5	24.4	30	27	15.1	24.4	28.6
20	1/2	M20-U-F8-	55.0	26.0	32	30	10.4	22.9	22.2
20	1	M20-U-F16-	62.8	26.0	32	35	15.9	31.2	38.1
25	1	M25-U-F16-	65.0	31.3	38	35	21.8	31.2	38.1

Переходные муфты

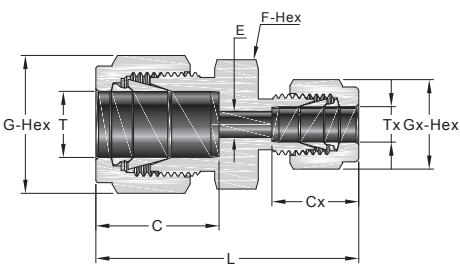

Дюймовая трубка

Трубка, дюйм	Трубка, дюйм	Артикул для заказа	Размеры, мм						
			L	C	G	F	E	Cx	Gx
1/8	1/16	F2-U-F1-	31.0	12.7	11.1	11.1	1.3	8.6	7.9
3/16	1/16	F3-U-F1-	32.3	13.7	12.7	11.1	1.3	8.6	7.9
3/16	1/8	F3-U-F2-	36.6	13.7	12.7	11.1	2.3	12.7	11.1
1/4	1/16	F4-U-F1-	34.3	15.2	14.3	12.7	1.3	8.6	7.9
1/4	1/8	F4-U-F2-	38.6	15.2	14.3	12.7	2.3	12.7	11.1
1/4	3/16	F4-U-F3-	39.4	15.2	14.3	12.7	3.0	13.7	12.7
5/16	1/8	F5-U-F2-	39.6	16.2	15.9	14.3	2.3	12.7	11.1
5/16	1/4	F5-U-F4-	42.2	16.2	15.9	14.3	4.8	15.2	14.3
3/8	1/16	F6-U-F1-	36.6	16.8	17.5	15.9	1.3	8.6	7.9
3/8	1/8	F6-U-F2-	40.9	16.8	17.5	15.9	2.3	12.7	11.1
3/8	1/4	F6-U-F4-	43.2	16.8	17.5	15.9	4.8	15.2	14.3
3/8	5/16	F6-U-F5-	44.2	16.8	17.5	15.9	6.4	16.2	15.9
1/2	1/8	F8-U-F2-	45.2	22.8	22.2	20.6	2.3	12.7	11.1
1/2	1/4	F8-U-F4-	47.0	22.8	22.2	20.6	4.8	15.2	14.3
1/2	3/8	F8-U-F6-	48.5	22.8	22.2	20.6	7.1	16.8	17.5
5/8	3/8	F10-U-F6-	49.3	24.4	25.4	23.9	7.1	16.8	17.5
5/8	1/2	F10-U-F8-	52.1	24.4	25.4	23.9	10.4	22.8	22.2
3/4	1/4	F12-U-F4-	49.3	24.4	28.6	27.0	4.8	15.2	14.3
3/4	3/8	F12-U-F6-	50.8	24.4	28.6	27.0	7.1	16.8	17.5
3/4	1/2	F12-U-F8-	53.6	24.4	28.6	27.0	10.4	22.8	22.2
3/4	5/8	F12-U-F10-	53.6	24.4	28.6	27.0	12.7	24.4	25.4
1	1/2	F16-U-F8-	60.5	31.2	38.1	34.9	10.4	22.8	22.2
1	3/4	F16-U-F12-	60.5	31.2	38.1	34.9	15.7	24.4	28.6

Переходные муфты

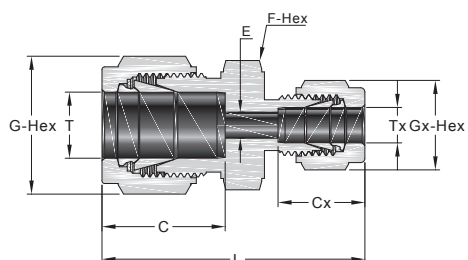

Метрическая трубка

Трубка, мм	Трубка, мм	Артикул для заказа	Размеры, мм						
			L	C	G	F	E	Cx	Gx
3	2	M3-U-M2-	35.3	12.9	12	12	1.7	12.9	12
6	2	M6-U-M2-	38.6	15.3	14	14	1.7	12.9	12
6	3	M6-U-M3-	38.6	15.3	14	14	2.4	12.9	12
6	4	M6-U-M4-	39.4	15.3	14	14	2.4	13.7	12
8	6	M8-U-M6-	42.3	16.3	16	15	4.8	15.3	14
10	6	M10-U-M6-	44.5	17.2	19	18	4.8	15.3	14
10	8	M10-U-M8-	45.1	17.2	19	18	6.4	16.3	16
12	6	M12-U-M6-	47.0	22.8	22	22	4.8	15.3	14
12	8	M12-U-M8-	47.8	22.8	22	22	6.4	16.3	16
12	10	M12-U-M10-	48.7	22.8	22	22	7.9	17.2	19
16	10	M16-U-M10-	49.5	24.4	25	24	7.9	17.2	19
16	12	M16-U-M12-	52.0	24.4	25	24	9.5	22.8	22
18	12	M18-U-M12-	53.5	24.4	30	27	9.5	22.8	22
25	18	M25-U-M18-	61.0	31.3	38	35	15.1	24.4	30
25	20	M25-U-M20-	62.3	31.3	38	35	15.9	26.0	32
30	18	M30-U-M18-	75.4	39.6	50	46	15.1	24.4	30
30	20	M30-U-M20-	75.4	39.6	50	46	15.9	26.0	32
30	25	M30-U-M25-	80.1	39.6	50	46	21.8	31.3	38
32	18	M32-U-M18-	77.8	42.0	50	46	15.1	24.4	30
32	20	M32-U-M20-	77.8	42.0	50	46	15.9	26.0	32
32	25	M32-U-M25-	82.3	42.0	50	46	21.8	31.3	38
38	20	M38-U-M20-	87.5	49.4	60	55	15.9	26.0	32
38	25	M38-U-M25-	92.0	49.4	60	55	21.8	31.3	38
38	30	M38-U-M30-	104.6	49.4	60	55	26.2	39.6	50

Муфта с монтажом на панель

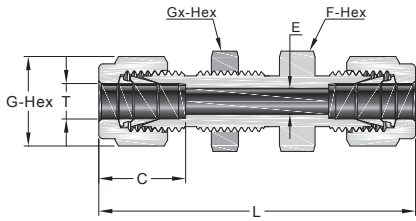

Дюймовая трубка

Трубка, дюйм	Артикул для заказа	Размеры, мм						Диаметр отверстия в панели, мм	Макс. толщина панели, мм
		L	C	E	G	F	Gx		
1/16	F1-BU-F1-	31.5	8.6	1.3	7.9	7.9	7.9	5.2	3.0
1/8	F2-BU-F2-	51.3	12.7	2.3	11.1	12.7	12.7	8.3	12.7
3/16	F3-BU-F3-	53.6	13.7	3.0	12.7	14.3	14.3	9.9	12.7
1/4	F4-BU-F4-	57.7	15.2	4.8	14.3	15.9	15.9	11.5	10.2
5/16	F5-BU-F5-	60.7	16.3	6.4	15.9	17.5	17.5	13.1	11.2
3/8	F6-BU-F6-	62.2	16.8	7.1	17.5	19.1	19.1	14.7	11.2
1/2	F8-BU-F8-	71.1	22.9	10.4	22.2	23.8	23.8	19.4	12.7
5/8	F10-BU-F10-	72.6	24.4	12.7	25.4	27.0	27.0	22.6	12.7
3/4	F12-BU-F12-	79.0	24.4	15.7	28.6	30.2	30.2	25.8	16.8
7/8	F14-BU-F14-	84.6	25.9	18.3	31.8	34.9	34.9	29.0	19.1
1	F16-BU-F16-	95.8	31.2	22.4	38.1	41.3	41.3	33.7	19.1
1 1/4	F20-BU-F20-	123.2	41.1	27.8	47.6	47.6	47.6	41.7	19.1
1 1/2	F24-BU-F24-	139.2	50.0	34.0	57.2	57.2	57.2	49.6	19.1

Метрическая трубка

Трубка, дюйм	Артикул для заказа	Размеры, мм						Диаметр отверстия в панели, мм	Макс. толщина панели, мм
		L	C	E	G	F	Gx		
3	M3-BU-M3-	51.3	12.9	2.4	12	14	14	8.3	12.7
4	M4-BU-M4-	53.6	13.7	2.4	12	14	14	9.9	12.7
6	M6-BU-M6-	57.7	15.3	4.8	14	16	16	11.5	10.2
8	M8-BU-M8-	61.0	16.2	6.4	16	18	18	13.1	11.2
10	M10-BU-M10-	63.7	17.2	7.9	19	22	22	16.3	11.2
12	M12-BU-M12-	71.0	22.8	9.5	22	24	24	19.5	12.7
14	M14-BU-M14-	72.5	24.4	11.1	25	27	27	22.5	12.7
15	M15-BU-M15-	72.5	24.4	11.9	25	27	27	22.8	12.7
16	M16-BU-M16-	72.5	24.4	12.7	25	27	27	22.8	12.7
18	M18-BU-M18-	78.9	24.4	15.1	30	30	30	26.0	16.8
20	M20-BU-M20-	84.5	26.0	15.9	32	35	35	29.0	19.0
25	M25-BU-M25-	96.0	31.3	21.8	38	41	41	34.0	19.0
30	M30-BU-M30-	124.0	39.6	26.2	50	50	50	40.5	19.0
32	M32-BU-M32-	128.0	42.0	28.6	50	50	50	42.5	19.0
38	M38-BU-M38-	145.0	49.4	33.7	60	60	60	50.5	19.0

Переходная муфта с монтажом на панель

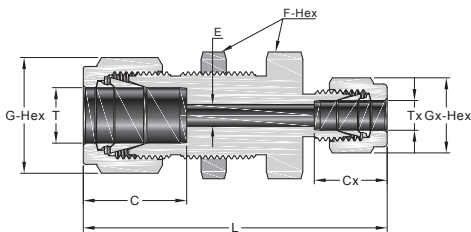

Дюймовая трубка

Т-Трубка, дюйм	Тх-Трубка, дюйм	Артикул для заказа	Размеры, мм								Диаметр отверстия в панели, мм	Макс. толщина панели, мм
			L	C	E	G	F	Cx	Gx			
1/4	1/8	F4-BU-F2-	55.1	15.2	2.3	14.3	15.9	12.7	11.1	11.5	10.2	
3/8	1/4	F6-BU-F4-	60.7	16.8	4.8	17.5	19.1	15.2	14.3	14.7	11.2	
1/2	1/4	F8-BU-F4-	66.8	22.9	4.8	22.2	23.8	15.2	14.3	19.4	12.7	

Bulkhead Reducing Unions

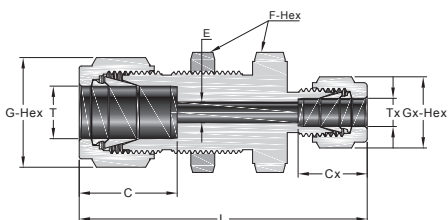

Метрическая трубка

Т-Трубка, мм	Тх-Трубка, мм	Артикул для заказа	Размеры, мм								Диаметр отверстия в панели, мм	Макс. толщина панели, мм
			L	C	E	G	F	Cx	Gx			
6	3	M6-BU-M3-	55.1	15.3	2.4	14	16	12.9	12	11.5	10.2	
8	6	M8-BU-M6-	60.1	16.2	4.8	16	18	15.3	14	13.1	11.2	
12	8	M12-BU-M8-	67.6	22.8	6.4	22	24	16.2	16	19.5	12.7	

Угольник с внешней резьбой

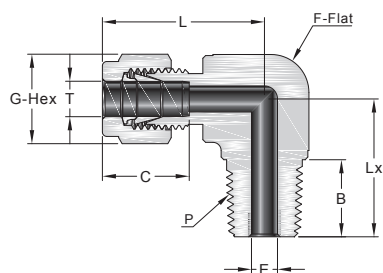

Дюймовая трубка

Резьба NPT

Трубка, дюйм	P-NPT Резьба	Артикул для заказа	Размеры, мм						
			L	C	G	F	E	B	Lx
1/16	1/16	F1-ME-NPT1-	19.1	8.6	7.9	11.1	1.3	9.7	17.8
1/16	1/8	F1-ME-NPT2-	19.1	8.6	7.9	11.1	1.3	9.7	17.8
1/8	1/16	F2-ME-NPT1-	23.6	12.7	11.1	11.1	2.4	9.7	17.8
1/8	1/8	F2-ME-NPT2-	23.6	12.7	11.1	11.1	2.4	9.7	17.8
1/8	1/4	F2-ME-NPT4-	24.6	12.7	11.1	12.7	2.4	14.2	23.4
3/16	1/8	F3-ME-NPT2-	25.4	13.7	12.7	12.7	3.0	9.7	18.8
3/16	1/4	F3-ME-NPT4-	25.4	13.7	12.7	12.7	3.0	14.2	23.4
1/4	1/16	F4-ME-NPT1-	26.9	15.2	14.3	12.7	3.0	9.7	18.8
1/4	1/8	F4-ME-NPT2-	26.9	15.2	14.3	12.7	4.8	9.7	18.8
1/4	1/4	F4-ME-NPT4-	26.9	15.2	14.3	12.7	4.8	14.2	23.4
1/4	3/8	F4-ME-NPT6-	29.7	15.2	14.3	17.5	4.8	14.2	26.2
1/4	1/2	F4-ME-NPT8-	31.8	15.2	14.3	20.6	4.8	19.1	33.0
5/16	1/8	F5-ME-NPT2-	28.7	16.3	15.9	14.3	4.8	9.7	19.8
5/16	1/4	F5-ME-NPT4-	28.7	16.3	15.9	14.3	6.4	14.2	24.4
5/16	3/8	F5-ME-NPT6-	30.5	16.3	15.9	17.5	6.4	14.2	26.2
3/8	1/8	F6-ME-NPT2-	30.5	16.8	17.5	15.9	4.8	9.7	20.8
3/8	1/4	F6-ME-NPT4-	30.5	16.8	17.5	15.9	7.1	14.2	25.4
3/8	3/8	F6-ME-NPT6-	31.2	16.8	17.5	17.5	7.1	14.2	26.2
3/8	1/2	F6-ME-NPT8-	33.3	16.8	17.5	20.6	7.1	19.1	33.0
3/8	3/4	F6-ME-NPT12-	37.1	16.8	17.5	27.0	7.1	19.1	36.8
1/2	1/4	F8-ME-NPT4-	36.1	22.9	22.2	20.6	7.1	14.2	28.2
1/2	3/8	F8-ME-NPT6-	36.1	22.9	22.2	20.6	9.7	14.2	28.2
1/2	1/2	F8-ME-NPT8-	36.1	22.9	22.2	20.6	10.4	19.1	33.0
1/2	3/4	F8-ME-NPT12-	39.9	22.9	22.2	27.0	10.4	19.1	36.8
5/8	3/8	F10-ME-NPT6-	38.1	24.4	25.4	23.8	9.7	14.2	30.2
5/8	1/2	F10-ME-NPT8-	38.1	24.4	25.4	23.8	11.9	19.1	35.1
5/8	3/4	F10-ME-NPT12-	39.9	24.4	25.4	27.0	12.7	19.1	36.8
3/4	1/2	F12-ME-NPT8-	39.9	24.4	28.6	27.0	11.9	19.1	36.8
3/4	3/4	F12-ME-NPT12-	39.9	24.4	28.6	27.0	15.7	19.1	36.8
7/8	3/4	F14-ME-NPT12-	44.7	25.9	31.8	34.9	15.7	19.1	41.7
1	3/4	F16-ME-NPT12-	49.0	31.2	38.1	34.9	15.7	19.1	41.7
1	1	F16-ME-NPT16-	49.0	31.2	38.1	34.9	22.4	23.9	46.5
1 1/4	1 1/4	F20-ME-NPT20-	66.5	41.1	47.6	42.9	27.7	23.9	52.4
1 1/2	1 1/2	F24-ME-NPT24-	78.0	50.0	57.2	50.8	34.0	26.2	60.5

Угольник с внешней резьбой

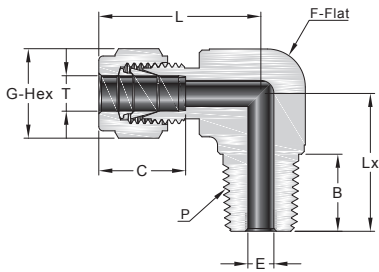

Метрическая трубка

Резьба NPT

Трубка, мм	P-NPT Резьба	Артикул для заказа	Размеры, мм						
			L	C	G	F	E	B	Lx
3	1/8	M3-ME-NPT2-	23.6	12.9	12	11.1	2.4	9.7	17.8
3	1/4	M3-ME-NPT4-	24.6	12.9	12	12.7	2.4	14.2	23.4
4	1/8	M4-ME-NPT2-	25.4	13.7	12	12.7	2.4	9.7	18.8
4	1/4	M4-ME-NPT4-	25.4	13.7	12	12.7	2.4	14.2	23.4
6	1/8	M6-ME-NPT2-	27.0	15.3	14	12.7	4.8	9.7	18.8
6	1/4	M6-ME-NPT4-	27.0	15.3	14	12.7	4.8	14.2	23.4
6	3/8	M6-ME-NPT6-	29.8	15.3	14	17.5	4.8	14.2	26.2
6	1/2	M6-ME-NPT8-	31.8	15.3	14	20.6	4.8	19.0	33.0
8	1/8	M8-ME-NPT2-	28.8	16.2	16	14.3	4.8	9.7	19.8
8	1/4	M8-ME-NPT4-	28.8	16.2	16	14.3	6.4	14.2	24.4
8	3/8	M8-ME-NPT6-	30.6	16.2	16	17.5	6.4	14.2	26.2
8	1/2	M8-ME-NPT8-	32.6	16.2	16	20.6	6.4	19.1	33.0
10	1/8	M10-ME-NPT2-	31.5	17.2	19	17.5	4.8	9.7	21.6
10	1/4	M10-ME-NPT4-	31.5	17.2	19	17.5	7.1	14.2	26.2
10	3/8	M10-ME-NPT6-	31.5	17.2	19	17.5	7.9	14.2	26.2
10	1/2	M10-ME-NPT8-	33.5	17.2	19	20.6	7.9	19.1	33.0
12	1/8	M12-ME-NPT2-	36.0	22.8	22	20.6	4.8	9.7	23.6
12	1/4	M12-ME-NPT4-	36.0	22.8	22	20.6	7.1	14.2	28.2
12	3/8	M12-ME-NPT6-	36.0	22.8	22	20.6	9.5	14.2	28.2
12	1/2	M12-ME-NPT8-	36.0	22.8	22	20.6	9.5	19.1	33.0
12	3/4	M12-ME-NPT12-	39.8	22.8	22	27.0	9.5	19.1	36.8
15	1/2	M15-ME-NPT8-	38.0	24.4	25	23.8	11.9	19.1	35.1
16	1/4	M16-ME-NPT4-	38.0	24.4	25	23.8	7.1	14.2	30.2
16	3/8	M16-ME-NPT6-	38.0	24.4	25	23.8	9.5	14.2	30.2
16	1/2	M16-ME-NPT8-	38.0	24.4	25	23.8	11.9	19.1	35.1
16	3/4	M16-ME-NPT12-	39.8	24.4	25	27.0	12.7	19.1	36.8
18	1/2	M18-ME-NPT8-	39.8	24.4	30	27.0	11.9	19.1	36.8
18	3/4	M18-ME-NPT12-	39.8	24.4	30	27.0	15.1	19.1	36.8
20	1/2	M20-ME-NPT8-	44.6	26.0	32	34.9	11.9	19.1	41.7
20	3/4	M20-ME-NPT12-	44.6	26.0	32	34.9	15.9	19.1	41.7
22	3/4	M22-ME-NPT12-	44.6	26.0	32	34.9	15.9	19.1	41.7
22	1	M22-ME-NPT16-	44.6	26.0	32	34.9	18.3	23.9	46.5
25	3/4	M25-ME-NPT12-	49.1	31.3	38	34.9	15.9	19.0	41.7
25	1	M25-ME-NPT16-	49.1	31.3	38	34.9	21.8	23.9	46.5
30	1 1/4	M30-ME-NPT20-	69.9	39.6	50	42.9	26.2	23.9	53.1
32	1 1/4	M32-ME-NPT20-	72.3	42.0	50	42.9	27.8	23.9	53.1
38	1 1/2	M38-ME-NPT24-	84.0	49.4	60	50.8	33.7	26.2	60.4

Угольник с внешней резьбой

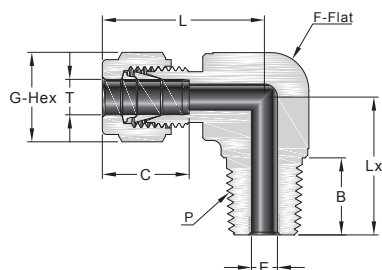

Дюймовая трубка

Коническая резьба ISO (BSPT)

Трубка, дюйм	P-BSPT Резьба	Артикул для заказа	Размеры, мм						
			L	C	G	F	E	B	Lx
1/8	1/8	F2-ME-MBT2-	23.6	12.7	11.1	11.1	2.4	9.7	17.8
1/8	1/4	F2-ME-MBT4-	24.6	12.7	11.1	12.7	2.4	14.2	23.4
1/4	1/8	F4-ME-MBT2-	26.9	15.2	14.3	12.7	4.8	9.7	18.8
1/4	1/4	F4-ME-MBT4-	26.9	15.2	14.3	12.7	4.8	14.2	23.4
1/4	3/8	F4-ME-MBT6-	29.7	15.2	14.3	17.5	4.8	14.2	26.2
1/4	1/2	F4-ME-MBT8-	31.8	15.2	14.3	20.6	4.8	19.1	33.0
5/16	1/4	F5-ME-MBT4-	28.7	16.3	15.9	14.3	6.4	14.2	24.4
3/8	1/8	F6-ME-MBT2-	30.5	16.8	17.5	15.9	4.8	9.7	20.8
3/8	1/4	F6-ME-MBT4-	30.5	16.8	17.5	15.9	7.1	14.2	25.4
3/8	3/8	F6-ME-MBT6-	31.2	16.8	17.5	17.5	7.1	14.2	26.2
1/2	3/8	F8-ME-MBT6-	36.1	22.9	22.2	20.6	9.7	14.2	27.9
1/2	1/2	F8-ME-MBT8-	36.1	22.9	22.2	20.6	10.4	19.1	33.0
3/4	1/2	F12-ME-MBT8-	39.9	24.4	28.6	27.0	11.9	19.1	36.8
1	1	F16-ME-MBT16-	49.0	31.2	38.1	34.9	22.4	23.9	46.5

Метрическая трубка

Коническая резьба ISO (BSPT)

Трубка, мм	P-BSPT Резьба	Артикул для заказа	Размеры, мм						
			L	C	G	F	E	B	Lx
3	1/8	M3-ME-MBT2-	23.6	12.9	12	11.1	2.4	9.7	17.8
3	1/4	M3-ME-MBT4-	24.6	12.9	12	12.7	2.4	14.2	23.4
4	1/8	M4-ME-MBT2-	25.4	13.7	12	12.7	2.4	9.7	18.8
4	1/4	M4-ME-MBT4-	25.4	13.7	12	12.7	2.4	14.2	23.4
6	1/8	M6-ME-MBT2-	27.0	15.3	14	12.7	4.8	9.7	18.8
6	1/4	M6-ME-MBT4-	27.0	15.3	14	12.7	4.8	14.2	23.4
6	3/8	M6-ME-MBT6-	29.8	15.3	14	17.5	4.8	14.2	26.2
6	1/2	M6-ME-MBT8-	31.8	15.3	14	20.6	4.8	19.0	33.0
8	1/8	M8-ME-MBT2-	28.8	16.2	16	14.3	4.8	9.7	19.8
8	1/4	M8-ME-MBT4-	28.8	16.2	16	14.3	6.4	14.2	24.4
8	3/8	M8-ME-MBT6-	30.6	16.2	16	17.5	6.4	14.2	26.2
8	1/2	M8-ME-MBT8-	32.6	16.2	16	20.6	6.4	19.1	33.0
10	1/8	M10-ME-MBT2-	31.5	17.2	19	17.5	4.8	9.7	21.6
10	1/4	M10-ME-MBT4-	31.5	17.2	19	17.5	7.1	14.2	26.2
10	3/8	M10-ME-MBT6-	31.5	17.2	19	17.5	7.9	14.2	26.2
10	1/2	M10-ME-MBT8-	33.5	17.2	19	20.6	7.9	19.1	33.0
12	1/8	M12-ME-MBT2-	36.0	22.8	22	20.6	4.8	9.7	23.6
12	1/4	M12-ME-MBT4-	36.0	22.8	22	20.6	7.1	14.2	28.2
12	3/8	M12-ME-MBT6-	36.0	22.8	22	20.6	9.5	14.2	28.2
12	1/2	M12-ME-MBT8-	36.0	22.8	22	20.6	9.5	19.1	33.0
12	3/4	M12-ME-MBT12-	39.8	22.8	22	27.0	9.5	19.1	36.8
14	1/2	M14-ME-MBT8-	38.1	24.4	25	23.8	11.1	19.1	35.1
15	1/2	M15-ME-MBT8-	38.1	24.4	25	23.8	11.9	19.1	35.1
16	1/4	M16-ME-MBT4-	38.0	24.4	25	23.8	7.1	14.2	30.2
16	3/8	M16-ME-MBT6-	38.0	24.4	25	23.8	9.5	14.2	30.2
16	1/2	M16-ME-MBT8-	38.0	24.4	25	23.8	11.9	19.1	35.1
16	3/4	M16-ME-MBT12-	39.8	24.4	25	27.0	12.7	19.1	36.8
18	1/2	M18-ME-MBT8-	39.8	24.4	30	27.0	11.9	19.1	36.8
18	3/4	M18-ME-MBT12-	39.8	24.4	30	27.0	15.1	19.1	36.8
20	1/2	M20-ME-MBT8-	44.6	26.0	32	34.9	11.9	19.1	41.7
20	3/4	M20-ME-MBT12-	44.6	26.0	32	34.9	15.9	19.1	41.7
22	3/4	M22-ME-MBT12-	44.6	26.0	32	34.9	15.9	19.1	41.7
22	1	M22-ME-MBT16-	44.6	26.0	32	34.9	18.3	23.9	46.5
25	3/4	M25-ME-MBT12-	49.1	31.3	38	34.9	15.9	19.1	41.7
25	1	M25-ME-MBT16-	49.1	31.3	38	34.9	21.8	23.9	46.5
28	1	M28-ME-MBT16-	64.0	36.6	46	42.9	21.8	23.9	53.1

Угольник под 45° с внешней резьбой

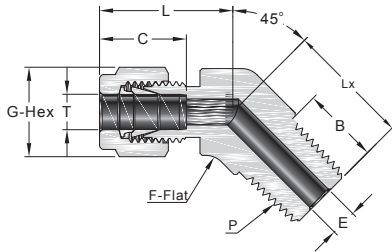

Дюймовая трубка

Резьба NPT

Трубка, дюйм	P-NPT Резьба	Артикул для заказа	Размеры, мм						
			L	C	G	F	E	B	Lx
1/16	1/16	F1-45ME-NPT1-	15.7	8.6	7.9	9.5	1.3	9.7	14.5
1/8	1/8	F2-45ME-NPT2-	20.8	12.7	11.1	11.1	2.3	9.7	16.8
3/16	1/8	F3-45ME-NPT2-	21.6	13.7	12.7	11.1	3.0	9.7	14.7
1/4	1/8	F4-45ME-NPT2-	24.6	15.2	14.3	12.7	4.8	9.7	16.5
1/4	1/4	F4-45ME-NPT4-	24.6	15.2	14.3	12.7	4.8	14.3	21.1
5/16	1/8	F5-45ME-NPT2-	24.1	16.3	15.9	14.3	4.8	9.7	16.8
3/8	1/8	F6-45ME-NPT2-	27.9	16.8	17.5	15.9	4.8	9.7	18.3
3/8	1/4	F6-45ME-NPT4-	27.9	16.8	17.5	15.9	7.1	14.3	22.9
3/8	3/8	F6-45ME-NPT6-	29.2	16.8	17.5	20.6	7.1	19.1	24.1
1/2	3/8	F8-45ME-NPT6-	32.0	22.9	22.2	20.6	9.7	19.1	24.1
5/8	1/2	F10-45ME-NPT8-	30.7	24.4	25.4	23.8	11.9	19.1	29.7
3/4	3/4	F12-45ME-NPT12-	34.0	24.4	28.6	27.0	15.7	19.1	31.0
7/8	3/4	F14-45ME-NPT12-	40.4	25.9	31.8	31.8	15.7	19.1	32.3
1	1	F16-45ME-NPT16-	40.4	31.2	38.1	34.9	22.4	23.9	37.8

Метрическая трубка

Резьба NPT

Трубка, мм	P-NPT Резьба	Артикул для заказа	Размеры, мм						
			L	C	G	F	E	B	Lx
6	1/8	M6-45ME-NPT2-	23.4	15.3	14	12.7	4.8	9.7	16.8
6	1/4	M6-45ME-NPT4-	23.4	15.3	14	12.7	4.8	14.3	21.8
8	1/8	M8-45ME-NPT2-	24.3	16.2	16	15.9	4.8	9.7	16.8
10	1/4	M10-45ME-NPT4-	26.6	17.2	19	17.5	7.9	14.3	24.1
12	3/8	M12-45ME-NPT6-	29.1	22.8	22	20.6	9.5	19.1	24.1
12	1/2	M12-45ME-NPT8-	30.7	22.8	22	20.6	9.5	19.1	29.7
16	1/2	M16-45ME-NPT8-	30.7	24.4	25	23.8	11.9	19.1	29.7

Позиционируемый угольник с внешней резьбой

Прямая резьба SAE/MS

Адаптер по стандартам SAE J1926-1, ISO 11926-1 и MS 16142.

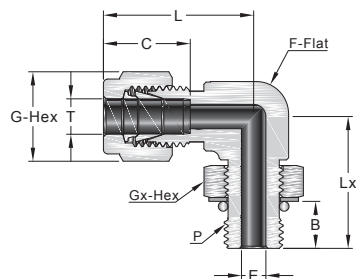

Дюймовая трубка

Прямая резьба SAE/MS

Трубка, дюйм	P-SAE/MS Резьба	Артикул для заказа	Размеры, мм							
			L	B	C	G	E	F	Lx	Gx
1/4	7/16-20	F4-PME-PST7-	28.4	9.9	15.2	14.3	4.8	12.7	28.4	14.3
1/4	9/16-18	F4-PME-PST9-	30.5	11.2	15.2	14.3	4.8	15.9	32.3	17.5
5/16	1/2-20	F5-PME-PST8-	30.2	9.9	16.3	15.9	5.8	14.3	29.5	15.9
3/8	7/16-20	F6-PME-PST7-	33.3	9.9	16.8	17.5	5.1	15.9	31.5	14.3
3/8	9/16-18	F6-PME-PST9-	32.0	11.2	16.8	17.5	7.1	15.9	32.3	17.5
3/8	3/4-16	F6-PME-PST12-	34.8	12.7	16.8	17.5	7.1	20.6	37.8	22.2
1/2	9/16-18	F8-PME-PST9-	37.6	11.2	22.9	22.2	7.1	20.6	37.5	17.5
1/2	3/4-16	F8-PME-PST12-	37.6	12.7	22.9	22.2	10.4	20.6	37.8	22.2
5/8	7/8-14	F10-PME-PST14-	39.6	14.2	24.4	25.4	12.7	23.8	43.4	25.4
3/4	1 1/16-12	F12-PME-PST17-	41.4	16.8	24.4	28.6	15.7	27.0	48.8	31.8
7/8	1 3/16-12	F14-PME-PST19-	43.2	16.8	25.9	31.8	18.3	30.2	50.5	34.9
1	1 5/16-12	F16-PME-PST21-	50.5	16.8	31.2	38.1	22.4	34.9	53.6	38.1
1 1/4	1 5/8-12	F20-PME-PST26-	67.8	16.8	41.1	47.6	27.7	42.9	58.2	47.6
1 1/2	1 7/8-12	F24-PME-PST30-	78.0	16.8	50.0	57.2	34.0	50.8	60.5	54.0

Позиционируемый угольник с внешней резьбой

Цилиндрическая резьба ISO

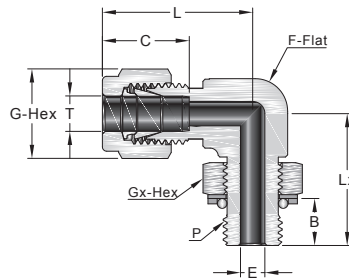

Дюймовая трубка

Цилиндрическая резьба ISO (PPT)

Трубка, дюйм	P-ISO Цилиндрическая резьба	Артикул для заказа	Размеры, мм							
			L	B	C	G	E	F	Lx	Gx
1/4	1/8	F4-PME-PPT2-	26.9	8.1	15.2	14.3	4.1	12.7	26.4	14.3
1/4	1/4	F4-PME-PPT4-	29.0	9.1	15.2	14.3	4.8	15.9	32.3	19.1
3/8	1/4	F6-PME-PPT4-	30.5	9.1	16.8	17.5	5.8	15.9	32.3	19.1
3/8	3/8	F6-PME-PPT6-	33.3	9.4	16.8	17.5	7.1	20.6	37.1	22.2
1/2	1/4	F8-PME-PPT4-	36.1	9.1	22.9	22.2	5.8	20.6	35.1	19.1
1/2	3/8	F8-PME-PPT6-	36.1	9.4	22.9	22.2	7.9	20.6	37.1	22.2
1/2	1/2	F8-PME-PPT8-	38.1	13.0	22.9	22.2	10.4	23.8	43.4	27.0
5/8	1/2	F10-PME-PPT8-	38.1	13.0	24.4	25.4	11.9	23.8	43.4	27.0
3/4	1/2	F12-PME-PPT8-	39.9	13.0	24.4	28.6	11.9	27.0	45.2	27.0
3/4	3/4	F12-PME-PPT12-	39.9	13.0	24.4	28.6	15.7	27.0	48.8	34.9
1	3/4	F16-PME-PPT12-	49.0	13.0	31.2	38.1	15.7	34.9	53.3	34.9
1	1	F16-PME-PPT16-	49.0	14.0	31.2	38.1	19.8	34.9	53.6	41.3

Метрическая трубка

Цилиндрическая резьба ISO (PPT)

Трубка, мм	P-ISO Цилиндрическая резьба	Артикул для заказа	Размеры, мм							
			L	B	C	G	E	F	Lx	Gx
6	1/8	M6-PME-PPT2-	27.0	8.1	15.3	14	4.0	12.7	26.4	14.3
6	1/4	M6-PME-PPT4-	29.0	9.1	15.3	14	4.8	15.9	32.3	19.1
8	1/8	M8-PME-PPT2-	28.8	8.1	16.2	16	4.0	14.3	27.4	14.3
8	1/4	M8-PME-PPT4-	29.9	9.1	16.2	16	5.9	15.9	32.2	19.1
10	1/4	M10-PME-PPT4-	33.5	9.1	17.2	19	5.9	20.6	35.0	19.1
10	3/8	M10-PME-PPT6-	33.5	9.4	17.2	19	7.9	20.6	37.1	22.2
12	1/4	M12-PME-PPT4-	36.0	9.1	22.8	22	5.9	20.6	35.0	19.1
12	3/8	M12-PME-PPT6-	36.0	9.4	22.8	22	7.9	20.6	37.1	22.2
12	1/2	M12-PME-PPT8-	38.0	13.0	22.8	22	9.5	23.8	43.4	27.0
12	3/4	M12-PME-PPT12-	39.8	13.0	22.8	22	9.5	27.0	48.8	34.9

Позиционируемый угольник под 45° с внешней резьбой

Прямая резьба SAE/MS

Адаптер по стандартам SAE J1926-1, ISO 11926-1 и MS 16142.

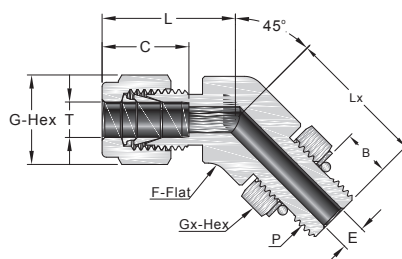

Дюймовая трубка

Прямая резьба SAE/MS

Трубка, дюйм	P-SAE/MS Резьба	Артикул для заказа	Размеры, мм							
			L	B	C	G	E	F	Lx	Gx
1/4	7/16-20	F4-45PME-PST7-	25.7	9.9	15.2	14.3	4.8	12.7	25.7	14.3
3/8	9/16-18	F6-45PME-PST9-	27.9	11.2	16.8	17.5	7.1	15.9	28.2	17.5
1/2	3/4-16	F8-45PME-PST12-	32.0	12.7	22.9	22.2	10.4	20.6	32.3	22.2
3/4	1 1/16-12	F12-45PME-PST17-	39.9	16.8	24.4	28.6	15.7	27.0	47.2	31.8
1	1 5/16-12	F16-45PME-PST21-	47.5	16.8	31.2	38.1	22.4	33.3	50.5	38.1

Угольник с внутренней резьбой

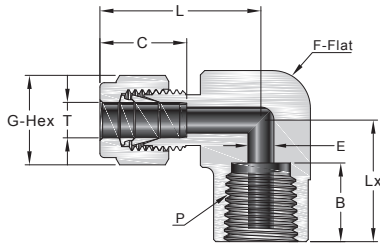

Дюймовая трубка

Резьба NPT

Трубка, дюйм	P-NPT Резьба	Артикул для заказа	Размеры, мм						
			L	B	C	G	E	F	Lx
1/16	1/16	F1-FE-FNPT1-	18.0	9.9	8.6	7.9	1.3	11.1	14.2
1/16	1/8	F1-FE-FNPT2-	20.6	10.4	8.6	7.9	1.3	14.3	19.1
1/8	1/8	F2-FE-FNPT2-	24.6	10.4	12.7	11.1	2.3	14.3	19.1
1/8	1/4	F2-FE-FNPT4-	27.4	15.0	12.7	11.1	2.3	17.5	22.4
3/16	1/8	F3-FE-FNPT2-	25.4	10.4	13.7	12.7	3.0	12.7	19.1
1/4	1/8	F4-FE-FNPT2-	26.9	10.4	15.2	14.3	4.8	14.3	19.1
1/4	1/4	F4-FE-FNPT4-	29.7	15.0	15.2	14.3	4.8	17.5	22.4
1/4	3/8	F4-FE-FNPT6-	31.8	15.0	15.2	14.3	4.8	20.6	22.4
1/4	1/2	F4-FE-FNPT8-	34.5	19.8	15.2	14.3	4.8	25.4	28.4
5/16	1/8	F5-FE-FNPT2-	28.7	10.4	16.3	15.9	6.4	14.3	19.1
5/16	1/4	F5-FE-FNPT4-	30.5	15.0	16.3	15.9	6.4	17.5	22.4
3/8	1/8	F6-FE-FNPT2-	30.5	10.4	16.8	17.5	7.1	15.9	19.1
3/8	1/4	F6-FE-FNPT4-	31.2	15.0	16.8	17.5	7.1	17.5	22.4
3/8	3/8	F6-FE-FNPT6-	33.3	15.0	16.8	17.5	7.1	20.6	22.4
3/8	1/2	F6-FE-FNPT8-	36.1	19.8	16.8	17.5	7.1	25.4	28.4
1/2	1/4	F8-FE-FNPT4-	36.1	15.0	22.9	22.2	10.4	20.6	22.4
1/2	3/8	F8-FE-FNPT6-	36.1	15.0	22.9	22.2	10.4	20.6	22.4
1/2	1/2	F8-FE-FNPT8-	38.9	19.8	22.9	22.2	10.4	25.4	28.4
5/8	3/8	F10-FE-FNPT6-	38.1	15.0	24.4	25.4	12.7	23.8	22.4
5/8	1/2	F10-FE-FNPT8-	39.9	19.8	24.4	25.4	12.7	27.0	28.4
3/4	1/2	F12-FE-FNPT8-	39.9	19.8	24.4	28.6	15.7	27.0	28.4
3/4	3/4	F12-FE-FNPT12-	44.7	20.6	24.4	28.6	15.7	34.9	31.8
7/8	3/4	F14-FE-FNPT12-	44.7	20.6	25.9	31.8	18.3	34.9	31.8
1	3/4	F16-FE-FNPT12-	49.0	20.6	31.2	38.1	22.4	34.9	31.8
1	1	F16-FE-FNPT16-	53.6	25.4	31.2	38.1	22.4	42.9	38.1

Метрическая трубка

Резьба NPT

Трубка, мм	P-NPT Резьба	Артикул для заказа	Размеры, мм						
			L	B	C	G	E	F	Lx
6	1/8	M6-FE-FNPT2-	27.0	10.4	15.3	14	4.8	12.7	19.0
6	1/4	M6-FE-FNPT4-	29.8	15.0	15.3	14	4.8	17.5	22.4
8	1/8	M8-FE-FNPT2-	28.8	10.4	16.2	16	4.8	14.3	19.1
8	1/4	M8-FE-FNPT4-	30.6	15.0	16.2	16	6.4	17.5	22.4
10	1/4	M10-FE-FNPT4-	33.5	15.0	17.2	19	7.9	20.6	22.4
10	3/8	M10-FE-FNPT6-	33.5	15.0	17.2	19	7.9	20.6	22.4
10	1/2	M10-FE-FNPT8-	36.6	19.8	17.2	19	7.9	25.4	28.5
12	1/4	M12-FE-FNPT4-	36.0	15.0	22.8	22	7.9	20.6	22.4
12	3/8	M12-FE-FNPT6-	36.0	15.0	22.8	22	9.5	20.6	22.4
12	1/2	M12-FE-FNPT8-	38.8	19.8	22.8	22	9.5	25.4	28.4
16	3/8	M16-FE-FNPT6-	39.5	15.0	24.4	25	9.5	27.0	23.6
16	1/2	M16-FE-FNPT8-	39.5	19.8	24.4	25	12.7	27.0	28.5

Соединительный угольник

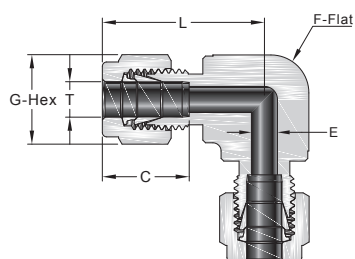

Дюймовая трубка

Трубка, дюйм	Артикул для заказа	Размеры, мм				
		L	C	G	F	E
1/16	F1-UE-F1-	17.8	8.6	7.9	9.5	1.3
1/8	F2-UE-F2-	22.4	12.7	11.1	9.5	2.3
3/16	F3-UE-F3-	25.4	13.7	12.7	12.7	3.0
1/4	F4-UE-F4-	26.9	15.2	14.3	12.7	4.8
5/16	F5-UE-F5-	28.7	16.3	15.9	14.3	6.4
3/8	F6-UE-F6-	30.5	16.8	17.5	15.9	7.1
1/2	F8-UE-F8-	36.1	22.9	22.2	20.6	10.4
5/8	F10-UE-F10-	38.1	24.4	25.4	23.8	12.7
3/4	F12-UE-F12-	39.9	24.4	28.6	27.0	15.7
7/8	F14-UE-F14-	44.7	25.9	31.8	34.9	18.3
1	F16-UE-F16-	49.0	31.2	38.1	34.9	22.4
1 1/8	F18-UE-F18-	55.1	31.2	41.3	42.9	24.6
1 1/4	F20-UE-F20-	66.5	41.1	47.6	42.9	27.7
1 1/2	F24-UE-F24-	78.0	50.0	57.2	50.8	34.0

Метрическая трубка

Трубка, мм	Артикул для заказа	Размеры, мм				
		L	C	G	F	E
3	M3-UE-M3-	22.3	12.9	12	9.5	2.4
4	M4-UE-M4-	25.4	13.7	12	12.7	2.4
6	M6-UE-M6-	27.0	15.3	14	12.7	4.8
8	M8-UE-M8-	28.8	16.2	16	14.3	6.4
10	M10-UE-M10-	31.5	17.2	19	17.5	7.9
12	M12-UE-M12-	36.0	22.8	22	20.6	9.5
14	M14-UE-M14-	38.0	24.4	25	23.8	11.0
15	M15-UE-M15-	38.8	24.4	25	23.8	11.9
16	M16-UE-M16-	38.0	24.4	25	23.8	12.7
18	M18-UE-M18-	39.8	24.4	30	27.0	15.1
20	M20-UE-M20-	44.6	26.0	32	34.9	15.9
22	M22-UE-M22-	44.6	26.0	32	34.9	18.3
25	M25-UE-M25-	49.1	31.3	38	34.9	21.8
28	M28-UE-M28-	64.0	36.6	46	42.9	21.8
30	M30-UE-M30-	69.9	39.6	50	42.9	26.2
32	M32-UE-M32-	72.3	42.0	50	42.9	28.6
38	M38-UE-M38-	84.0	49.4	60	50.8	33.7

Переходной угольник

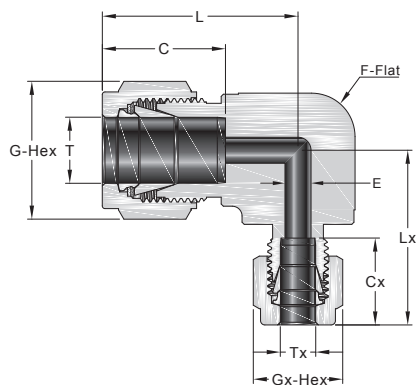

Дюймовая трубка

Т- Трубка, дюйм	Тх- Трубка, дюйм	Артикул для заказа	Размеры, мм								
			L	C	G	F	E	Cx	Gx	Lx	
3/16	1/8	F3-UE-F2-	25.4	13.7	12.7	12.7	2.3	12.7	11.1	24.7	
1/4	1/8	F4-UE-F2-	26.9	15.2	14.3	12.7	2.3	12.7	11.1	25.4	
5/16	1/8	F5-UE-F2-	29.7	16.3	15.9	14.3	2.3	12.7	11.1	26.4	
5/16	1/4	F5-UE-F4-	29.7	16.3	15.9	14.3	4.8	15.2	14.3	29.0	
3/8	1/8	F6-UE-F2-	30.5	16.8	17.5	15.9	2.3	12.7	11.1	26.4	
3/8	1/4	F6-UE-F4-	30.5	16.8	17.5	15.9	4.8	15.2	14.3	29.0	
3/8	5/16	F6-UE-F5-	30.5	16.8	17.5	15.9	6.4	16.3	15.9	29.7	
1/2	1/4	F8-UE-F4-	36.1	22.9	22.2	20.6	4.8	15.2	14.3	32.2	
1/2	5/16	F8-UE-F5-	36.1	22.9	22.2	20.6	6.4	16.3	15.9	32.5	
1/2	3/8	F8-UE-F6-	36.1	22.9	22.2	20.6	7.1	16.8	17.5	33.6	
5/8	3/8	F10-UE-F6-	38.1	24.4	25.4	23.8	7.1	16.8	17.5	35.6	
5/8	1/2	F10-UE-F8-	38.1	24.4	25.4	23.8	10.4	22.9	22.2	38.1	
3/4	1/4	F12-UE-F4-	39.9	24.4	28.6	27.0	4.8	15.2	14.3	35.9	
3/4	3/8	F12-UE-F6-	39.9	24.4	28.6	27.0	7.1	16.8	17.5	37.4	
3/4	1/2	F12-UE-F8-	39.9	24.4	28.6	27.0	10.4	22.9	22.2	39.9	
7/8	1/4	F14-UE-F4-	44.7	25.9	31.8	34.9	4.8	15.2	14.3	40.7	
1	1/2	F16-UE-F8-	49.0	31.2	38.1	34.9	10.4	22.9	22.2	44.4	
1	3/4	F16-UE-F12-	49.0	31.2	38.1	34.9	15.7	24.4	28.6	44.4	

Метрическая трубка

Т- Трубка, мм	Тх- Трубка, мм	Артикул для заказа	Размеры, мм								
			L	C	G	F	E	Cx	Gx	Lx	
8	6	M8-UE-M6-	28.8	16.2	16	14.3	4.8	15.3	14	27.9	
10	8	M10-UE-M8-	31.5	17.2	19	17.5	6.4	16.2	16	30.5	
12	8	M12-UE-M8-	36.0	22.8	22	20.6	6.4	16.2	16	32.6	
14	8	M14-UE-M8-	38.8	24.4	25	23.8	6.4	16.2	16	35.4	
14	10	M14-UE-M10-	38.8	24.4	25	23.8	7.9	17.2	19	36.4	

Тройник с внешней резьбой снизу

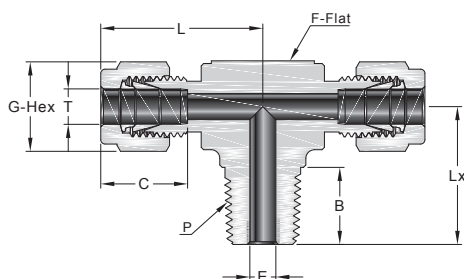

Дюймовая трубка

Резьба NPT

Трубка, дюйм	P-NPT Резьба	Артикул для заказа	Размеры, мм						
			L	C	G	F	E	B	Lx
1/8	1/8	F2-MBT-F2-NPT2-	23.6	12.7	11.1	11.1	2.3	9.7	17.8
1/8	1/4	F2-MBT-F2-NPT4-	24.6	12.7	11.1	12.7	2.3	14.2	23.4
3/16	1/8	F3-MBT-F3-NPT2-	24.4	13.7	12.7	11.1	3.0	9.7	17.8
1/4	1/8	F4-MBT-F4-NPT2-	26.9	15.2	14.3	12.7	4.8	9.7	18.8
1/4	1/4	F4-MBT-F4-NPT4-	26.9	15.2	14.3	12.7	4.8	14.2	23.4
5/16	1/8	F5-MBT-F5-NPT2-	29.7	16.3	15.9	15.9	4.8	9.7	20.8
5/16	1/4	F5-MBT-F5-NPT4-	29.7	16.3	15.9	15.9	6.4	14.2	25.7
3/8	1/4	F6-MBT-F6-NPT4-	30.5	16.8	17.5	15.9	7.1	14.2	25.4
3/8	3/8	F6-MBT-F6-NPT6-	33.3	16.8	17.5	20.6	7.1	14.2	28.2
1/2	3/8	F8-MBT-F8-NPT6-	36.1	22.9	22.2	20.6	9.7	14.2	28.2
1/2	1/2	F8-MBT-F8-NPT8-	36.1	22.9	22.2	20.6	10.4	19.1	33.0
5/8	1/2	F10-MBT-F10-NPT8-	38.9	24.4	25.4	25.4	11.9	19.1	35.8
3/4	3/4	F12-MBT-F12-NPT12-	39.9	24.4	28.6	27.0	15.7	19.1	36.8
7/8	3/4	F14-MBT-F14-NPT12-	44.7	25.9	31.8	33.3	15.7	19.1	38.1
1	3/4	F16-MBT-F16-NPT12-	49.3	31.2	38.1	33.3	15.7	19.1	42.2
1	1	F16-MBT-F16-NPT16-	49.3	31.2	38.1	34.9	22.4	23.9	46.7

Метрическая трубка

Резьба NPT

Трубка, мм	P-NPT Резьба	Артикул для заказа	Размеры, мм						
			L	C	G	F	E	B	Lx
6	1/8	M6-MBT-M6-NPT2-	27.0	15.3	14	12.7	4.8	9.7	18.8
6	1/4	M6-MBT-M6-NPT4-	27.0	15.3	14	12.7	4.8	14.2	23.4
8	1/8	M8-MBT-M8-NPT2-	29.9	16.2	16	15.9	4.8	9.7	20.8
8	1/4	M8-MBT-M8-NPT4-	29.9	16.2	16	15.9	6.4	14.2	25.4
10	1/4	M10-MBT-M10-NPT4-	33.5	17.2	19	20.6	7.9	14.2	28.2
10	3/8	M10-MBT-M10-NPT6-	33.5	17.2	19	20.6	7.9	14.2	28.2
12	1/4	M12-MBT-M12-NPT4-	36.0	22.8	22	20.6	7.9	14.2	28.2
12	3/8	M12-MBT-M12-NPT6-	36.0	22.8	22	20.6	9.5	14.2	28.2
12	1/2	M12-MBT-M12-NPT8-	36.0	22.8	22	20.6	9.5	19.1	33.0
16	1/2	M16-MBT-M16-NPT8-	38.8	24.4	25	25.4	11.9	19.1	35.8

Тройник с внешней резьбой сбоку

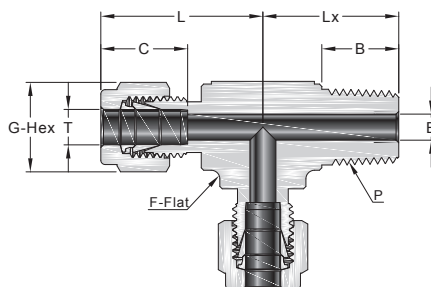

Дюймовая трубка

Резьба NPT

Трубка, дюйм	P-NPT Резьба	Артикул для заказа	Размеры, мм						
			L	C	G	F	E	B	Lx
1/8	1/8	F2-MRT-NPT2-F2-	23.6	12.7	11.1	11.1	2.3	9.7	17.8
1/8	1/4	F2-MRT-NPT4-F2-	24.6	12.7	11.1	12.7	2.3	14.2	23.4
3/16	1/8	F3-MRT-NPT2-F3-	24.4	13.7	12.7	11.1	3.0	9.7	17.8
1/4	1/8	F4-MRT-NPT2-F4-	26.9	15.2	14.3	12.7	4.8	9.7	18.8
1/4	1/4	F4-MRT-NPT4-F4-	26.9	15.2	14.3	12.7	4.8	14.2	23.4
5/16	1/8	F5-MRT-NPT2-F5-	29.7	16.3	15.9	15.9	4.8	9.7	20.8
5/16	1/4	F5-MRT-NPT4-F5-	29.7	16.3	15.9	15.9	6.4	14.2	25.7
3/8	1/4	F6-MRT-NPT4-F6-	30.5	16.8	17.5	15.9	7.1	14.2	25.4
3/8	3/8	F6-MRT-NPT6-F6-	33.3	16.8	17.5	20.6	7.1	14.2	28.2
1/2	3/8	F8-MRT-NPT6-F8-	36.1	22.9	22.2	20.6	9.7	14.2	28.2
1/2	1/2	F8-MRT-NPT8-F8-	36.1	22.9	22.2	20.6	10.4	19.1	33.0
5/8	1/2	F10-MRT-NPT8-F10-	38.1	24.4	25.4	23.8	11.9	19.1	35.8
3/4	3/4	F12-MRT-NPT12-F12-	39.9	24.4	28.6	27.0	15.7	19.1	36.8
7/8	3/4	F14-MRT-NPT12-F14-	44.7	25.9	31.8	33.3	15.7	19.1	38.1
1	3/4	F16-MRT-NPT12-F16-	49.3	31.2	38.1	33.3	15.7	19.1	42.2
1	1	F16-MRT-NPT16-F16-	49.3	31.2	38.1	34.9	22.4	23.9	46.7

Метрическая трубка

Резьба NPT

Трубка, мм	P-NPT Резьба	Артикул для заказа	Размеры, мм						
			L	C	G	F	E	B	Lx
6	1/8	M6-MRT-NPT2-M6-	27.0	15.3	14	12.7	4.8	9.7	18.0
6	1/4	M6-MRT-NPT4-M6-	27.0	15.3	14	12.7	4.8	14.2	23.4
8	1/8	M8-MRT-NPT2-M8-	29.9	16.2	16	15.9	4.8	9.7	20.8
8	1/4	M8-MRT-NPT4-M8-	29.9	16.2	16	15.9	6.4	14.2	25.4
10	1/4	M10-MRT-NPT4-M10-	33.5	17.2	19	20.6	7.9	14.2	28.2
10	1/2	M10-MRT-NPT8-M10-	33.5	17.2	19	20.6	7.9	14.2	28.2
12	1/4	M12-MRT-NPT4-M12-	36.0	22.8	22	20.6	7.9	14.2	28.2
12	3/8	M12-MRT-NPT6-M12-	36.0	22.8	22	20.6	9.5	14.2	28.2
12	1/2	M12-MRT-NPT8-M12-	36.0	22.8	22	20.6	9.5	19.1	33.0
16	1/2	M16-MRT-NPT8-M16-	38.0	24.4	25	23.8	11.9	19.1	35.0

Позиционируемый тройник с внешней резьбой снизу

Прямая резьба SAE/MS

Адаптер по стандартам SAE J1926-1, ISO 11926-1 и MS 16142.

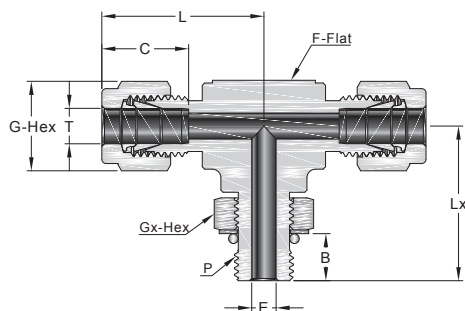

Дюймовая трубка

Прямая резьба SAE/MS

Трубка, дюйм	P-SAE/MS Резьба	Артикул для заказа	Размеры, мм							
			L	B	C	E	G	F	Lx	Gx
1/4	7/16-20	F4-PMBT-F4-PST7-	28.5	9.9	15.2	4.8	14.3	12.7	28.5	14.3
3/8	9/16-18	F6-PMBT-F6-PST9-	32.0	11.2	16.8	7.1	17.5	15.9	32.3	17.5
1/2	3/4-16	F8-PMBT-F8-PST12-	37.6	12.7	22.9	10.4	22.2	20.6	37.8	22.2
3/4	1 1/16-12	F12-PMBT-F12-PST17-	41.4	16.8	24.4	15.7	28.6	27.0	48.8	28.6
1	1 5/16-12	F16-PMBT-F16-PST21-	50.5	16.8	31.2	22.4	38.1	34.9	53.6	38.1
1 1/4	1 5/8-12	F20-PMBT-F20-PST26-	67.8	16.8	41.1	27.7	47.6	42.9	58.2	47.6
1 1/4	1 7/8-12	F24-PMBT-F24-PST30-	78.0	16.8	50.0	34.0	57.2	50.8	60.5	54.0

Позиционируемый тройник с внешней резьбой снизу

Цилиндрическая резьба ISO

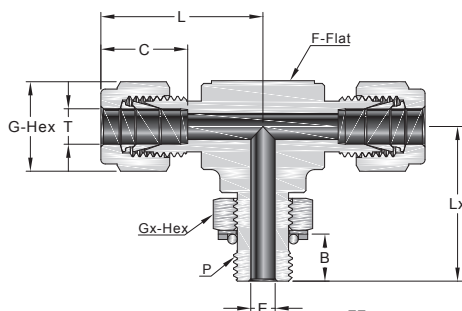

Дюймовая трубка

Цилиндрическая резьба ISO (PPT)

Трубка, дюйм	P-ISO Цилиндрическая резьба	Артикул для заказа	Размеры, мм							
			L	B	C	E	G	F	Lx	Gx
1/4	1/8	F4-PMBT-F4-PPT2-	26.9	8.1	15.2	4.1	14.3	12.7	26.4	14.3
1/4	1/4	F4-PMBT-F4-PPT4-	29.0	9.1	15.2	4.8	14.3	15.9	32.3	19.1
3/8	1/4	F6-PMBT-F6-PPT4-	30.5	9.1	16.8	5.8	17.5	15.9	32.3	19.1
1/2	3/8	F8-PMBT-F8-PPT6-	36.1	9.4	22.9	7.9	22.2	20.6	37.1	22.2
1/2	1/2	F8-PMBT-F8-PPT8-	38.1	13.0	22.9	10.4	22.2	23.8	43.4	27.0
5/8	1/2	F10-PMBT-F10-PPT8-	38.1	13.0	24.4	11.9	25.4	23.8	43.4	27.0
3/4	1/2	F12-PMBT-F12-PPT8-	39.9	13.0	24.4	11.9	28.6	27.0	45.2	27.0
3/4	3/4	F12-PMBT-F12-PPT12-	39.9	13.0	24.4	15.7	28.6	27.0	48.8	34.9
1	1	F16-PMBT-F16-PPT16-	49.0	14.0	31.2	19.8	38.1	34.9	53.6	41.3

Метрическая трубка

Цилиндрическая резьба ISO (PPT)

Трубка, мм	P-ISO Цилиндрическая резьба	Артикул для заказа	Размеры, мм							
			L	B	C	E	G	F	Lx	Gx
6	1/8	M6-PMBT-M6-PPT2-	27.0	8.1	15.3	4.0	14	12.7	26.4	14.3
6	1/4	M6-PMBT-M6-PPT4-	29.0	9.1	15.3	4.8	14	15.9	32.2	19.1
8	1/8	M8-PMBT-M8-PPT2-	28.8	8.1	16.2	4.0	16	14.3	27.5	14.3
8	1/4	M8-PMBT-M8-PPT4-	29.9	9.1	16.2	5.9	16	15.9	32.2	19.1
10	1/4	M10-PMBT-M10-PPT4-	33.5	9.1	17.2	5.9	19	20.6	35.1	19.1
12	3/8	M12-PMBT-M12-PPT6-	36.0	9.4	22.8	7.9	22	20.6	37.1	22.2
12	1/2	M12-PMBT-M12-PPT8-	38.0	13.0	22.8	9.5	22	23.8	43.5	27.0

Позиционируемый тройник с внешней резьбой сбоку

Прямая резьба SAE/MS

Адаптер по стандартам SAE J1926-1, ISO 11926-1 и MS 16142.

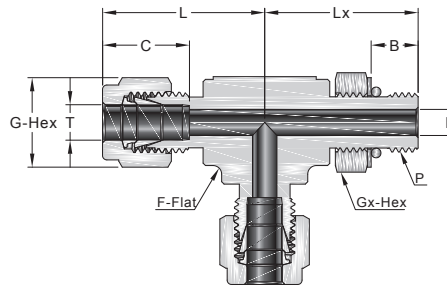

Дюймовая трубка

Прямая резьба SAE/MS

Трубка, дюйм	P-SAE/MS Резьба	Артикул для заказа	Размеры, мм							
			L	B	C	E	G	F	Lx	Gx
1/4	7/16-20	F4-PMRT-PST7-F4-	28.5	9.9	15.2	4.8	14.3	12.7	28.5	14.3
3/8	9/16-18	F6-PMRT-PST9-F6-	32.0	11.2	16.8	7.1	17.5	15.9	32.3	17.5
1/2	3/4-16	F8-PMRT-PST12-F8-	37.6	12.7	22.9	10.4	22.2	20.6	37.8	22.2
3/4	1 1/16-12	F12-PMRT-PST17-F12-	41.4	16.8	24.4	15.7	28.6	27.0	48.8	28.6
1	1 5/16-12	F16-PMRT-PST21-F16-	50.5	16.8	31.2	22.4	38.1	34.9	53.6	38.1
1 1/4	1 5/8-12	F20-PMRT-PST26-F20-	67.8	16.8	41.1	27.7	47.6	42.9	58.2	47.6
1 1/2	1 7/8-12	F24-PMRT-PST30-F24-	78.0	16.8	50.0	34.0	57.2	50.8	60.5	54.0

Позиционируемый тройник с внешней резьбой сбоку

Цилиндрическая резьба ISO

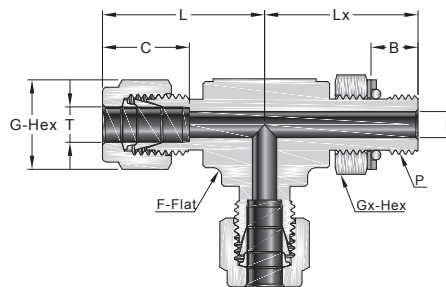

Дюймовая трубка

Цилиндрическая резьба ISO (PPT)

Трубка, дюйм	P-ISO Цилиндрическая резьба	Артикул для заказа	Размеры, мм							
			L	B	C	E	G	F	Lx	Gx
1/4	1/8	F4-PMRT-PPT2-F4-	26.9	8.1	15.2	4.1	14.3	12.7	26.4	14.3
1/4	1/4	F4-PMRT-PPT4-F4-	29.0	9.1	15.2	4.8	14.3	15.9	32.3	19.1
3/8	1/4	F6-PMRT-PPT4-F6-	30.5	9.1	16.8	5.8	17.5	15.9	32.3	19.1
1/2	3/8	F8-PMRT-PPT6-F8-	36.1	9.4	22.9	7.9	22.2	20.6	37.1	22.2
1/2	1/2	F8-PMRT-PPT8-F8-	38.1	13.0	22.9	10.4	22.2	23.8	43.4	27.0
5/8	1/2	F10-PMRT-PPT8-F10-	38.1	13.0	24.4	11.9	25.4	23.8	43.4	27.0
3/4	1/2	F12-PMRT-PPT8-F12-	39.9	13.0	24.4	11.9	28.6	27.0	45.2	27.0
3/4	3/4	F12-PMRT-PPT12-F12-	39.9	13.0	24.4	15.7	28.6	27.0	48.8	34.9
1	1	F16-PMRT-PPT16-F16-	49.0	14.0	31.2	19.8	38.1	34.9	53.6	41.3

Метрическая трубка

Цилиндрическая резьба ISO (PPT)

Трубка, мм	P-ISO Цилиндрическая резьба	Артикул для заказа	Размеры, мм							
			L	B	C	E	G	F	Lx	Gx
6	1/8	M6-PMRT-PPT2-M6-	27.0	8.1	15.3	4.0	14	12.7	26.4	14.3
6	1/4	M6-PMRT-PPT4-M6-	29.0	9.1	15.3	4.8	14	15.9	32.2	19.1
8	1/8	M8-PMRT-PPT2-M8-	28.8	8.1	16.2	4.0	16	14.3	27.5	14.3
8	1/4	M8-PMRT-PPT4-M8-	29.9	9.1	16.2	5.9	16	15.9	32.2	19.1
10	1/4	M10-PMRT-PPT4-M10-	33.5	9.1	17.2	5.9	19	20.6	35.1	19.1
12	3/8	M12-PMRT-PPT6-M12-	36.0	9.4	22.8	7.9	22	20.6	37.1	22.2
12	1/2	M12-PMRT-PPT8-M12-	38.0	13.0	22.8	9.5	22	23.8	43.5	27.0

Тройник с внутренней резьбой снизу

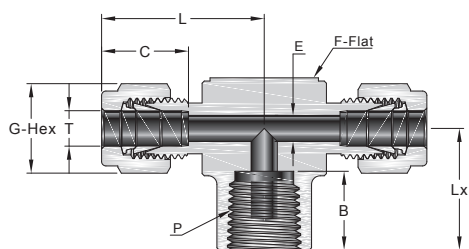

Дюймовая трубка

Резьба NPT

Трубка, дюйм	P-NPT Резьба	Артикул для заказа	Размеры, мм						
			L	C	G	F	E	B	Lx
1/8	1/8	F2-FBT-F2-FNPT2-	24.6	12.7	11.1	12.7	2.3	10.4	19.1
3/16	1/8	F3-FBT-F3-FNPT2-	25.7	13.7	12.7	12.7	3.0	10.4	19.1
1/4	1/8	F4-FBT-F4-FNPT2-	26.9	15.2	14.3	12.7	4.8	10.4	19.1
1/4	1/4	F4-FBT-F4-FNPT4-	29.7	15.2	14.3	17.5	4.8	15.0	22.4
5/16	1/8	F5-FBT-F5-FNPT2-	29.7	16.2	15.9	15.9	6.4	10.4	19.1
3/8	1/4	F6-FBT-F6-FNPT4-	31.2	16.8	17.5	17.5	7.1	15.0	22.4
3/8	3/8	F6-FBT-F6-FNPT6-	33.3	16.8	17.5	20.6	7.1	15.0	22.4
3/8	1/2	F6-FBT-F6-FNPT8-	36.1	16.8	17.5	25.4	7.1	19.8	28.4
1/2	1/4	F8-FBT-F8-FNPT4-	36.1	22.9	22.2	20.6	10.4	15.0	22.4
1/2	3/8	F8-FBT-F8-FNPT6-	36.1	22.9	22.2	20.6	10.4	15.0	22.4
1/2	1/2	F8-FBT-F8-FNPT8-	38.9	22.9	22.2	25.4	10.4	19.8	28.4
5/8	1/2	F10-FBT-F10-FNPT8-	38.9	24.4	25.4	25.4	12.7	19.8	28.4
3/4	3/4	F12-FBT-F12-FNPT12-	44.7	24.4	28.6	34.9	15.7	20.6	31.8
7/8	3/4	F14-FBT-F14-FNPT12-	44.7	25.9	31.8	34.9	18.3	20.6	31.8
1	3/4	F16-FBT-F16-FNPT12-	49.0	31.2	38.1	34.9	22.4	20.6	31.8
1	1	F16-FBT-F16-FNPT16-	53.6	31.2	38.1	42.9	22.4	25.4	38.1

Метрическая трубка

Резьба NPT

Трубка, мм	P-NPT Резьба	Артикул для заказа	Размеры, мм						
			L	C	G	F	E	B	Lx
6	1/8	M6-FBT-M6-FNPT2-	27.0	15.3	14	12.7	4.8	10.4	19.0
6	1/4	M6-FBT-M6-FNPT4-	29.8	15.3	14	17.5	4.8	15.0	22.4
8	1/8	M8-FBT-M8-FNPT2-	29.9	16.2	16	15.9	6.4	10.4	19.0
8	1/4	M8-FBT-M8-FNPT4-	30.6	16.2	16	17.5	6.4	15.0	22.4
10	1/4	M10-FBT-M10-FNPT4-	33.5	17.2	19	20.6	7.9	15.0	22.4
12	1/8	M12-FBT-M12-FNPT2-	36.0	22.8	22	20.6	6.4	10.4	22.3
12	1/4	M12-FBT-M12-FNPT4-	36.0	22.8	22	20.6	9.5	15.0	22.4
12	3/8	M12-FBT-M12-FNPT6-	36.0	22.8	22	20.6	9.5	15.0	22.4
12	1/2	M12-FBT-M12-FNPT8-	38.8	22.8	22	25.4	9.5	19.8	28.5
16	1/2	M16-FBT-M16-FNPT8-	38.8	24.4	25	25.4	12.7	19.8	28.4

Тройник с внутренней резьбой снизу

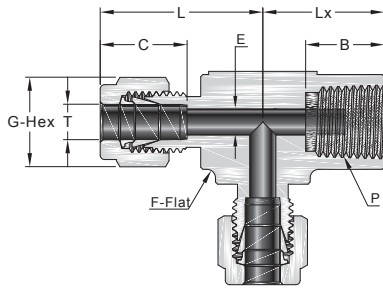

Дюймовая трубка

Резьба NPT

Трубка, дюйм	P-NPT Резьба	Артикул для заказа	Размеры, мм						
			L	C	G	F	E	B	Lx
1/8	1/8	F2-FRT-FNPT2-F2-	24.6	12.7	11.1	12.7	2.3	10.4	19.1
3/16	1/8	F3-FRT-FNPT2-F3-	25.7	13.7	12.7	12.7	3.0	10.4	19.1
1/4	1/8	F4-FRT-FNPT2-F4-	26.9	15.2	14.3	12.7	4.8	10.4	19.1
1/4	1/4	F4-FRT-FNPT4-F4-	29.7	15.2	14.3	17.5	4.8	15.0	22.4
5/16	1/8	F5-FRT-FNPT2-F5-	29.7	16.2	15.9	15.9	6.4	10.4	19.1
3/8	1/4	F6-FRT-FNPT4-F6-	31.2	16.8	17.5	17.5	7.1	15.0	22.4
1/2	1/4	F8-FRT-FNPT4-F8-	36.1	22.9	22.2	20.6	10.4	15.0	22.4
1/2	3/8	F8-FRT-FNPT6-F8-	36.1	22.9	22.2	20.6	10.4	15.0	22.4
1/2	1/2	F8-FRT-FNPT8-F8-	39.9	22.9	22.2	27.0	10.4	19.8	28.4
5/8	1/2	F10-FRT-FNPT8-F10-	39.9	24.4	25.4	27.0	12.7	19.8	28.4
3/4	3/4	F12-FRT-FNPT12-F12-	44.7	24.4	28.6	34.9	15.7	20.6	31.8
7/8	1/2	F14-FRT-FNPT8-F14-	44.7	25.9	31.8	34.9	15.7	19.8	28.4
7/8	3/4	F14-FRT-FNPT12-F14-	44.7	25.9	31.8	34.9	18.3	20.6	31.8
1	3/4	F16-FRT-FNPT12-F16-	49.0	31.2	38.1	34.9	22.4	20.6	31.8
1	1	F16-FRT-FNPT16-F16-	53.6	31.2	38.1	42.9	22.4	25.4	38.1

Метрическая трубка

Резьба NPT

Трубка, мм	P-NPT Резьба	Артикул для заказа	Размеры, мм						
			L	C	G	F	E	B	Lx
6	1/8	M6-FRT-FNPT2-M6-	27.0	15.3	14	12.7	4.8	10.4	19.0
6	1/4	M6-FRT-FNPT4-M6-	29.8	15.3	14	17.5	4.8	15.0	22.4
8	1/8	M8-FRT-FNPT2-M8-	29.9	16.2	16	15.9	4.8	10.4	19.0
8	1/4	M8-FRT-FNPT4-M8-	30.6	16.2	16	17.5	6.4	15.0	22.4
10	1/4	M10-FRT-FNPT4-M10-	33.5	17.2	19	20.6	7.9	15.0	22.4
12	1/4	M12-FRT-FNPT4-M12-	36.0	22.8	22	20.6	9.5	15.0	22.4
12	3/8	M12-FRT-FNPT6-M12-	36.0	22.8	22	20.6	9.5	15.0	23.1
12	1/2	M12-FRT-FNPT8-M12-	38.8	22.8	22	25.4	9.5	19.8	28.5
16	1/2	M16-FRT-FNPT8-M16-	39.8	24.4	25	27.0	11.9	19.8	28.4

Соединительный тройник

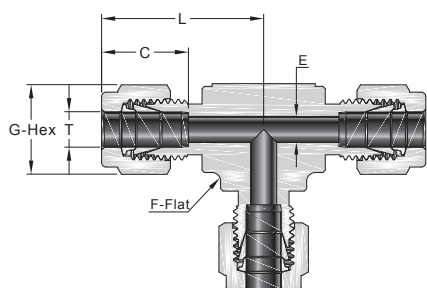

Дюймовая трубка

Трубка, дюйм	Артикул для заказа	Размеры, мм				
		L	C	G	F	E
1/16	F1-UT-F1-F1-	17.8	8.6	7.9	9.5	1.3
1/8	F2-UT-F2-F2-	22.4	12.7	11.1	9.5	2.3
3/16	F3-UT-F3-F3-	24.4	13.7	12.7	11.1	3.0
1/4	F4-UT-F4-F4-	26.9	15.2	14.3	12.7	4.8
5/16	F5-UT-F5-F5-	29.7	16.2	15.9	15.9	6.4
3/8	F6-UT-F6-F6-	30.5	16.8	17.5	15.9	7.1
1/2	F8-UT-F8-F8-	36.1	22.9	22.2	20.6	10.4
5/8	F10-UT-F10-F10-	38.9	24.4	25.4	25.4	12.7
3/4	F12-UT-F12-F12-	39.9	24.4	28.6	27.0	15.7
7/8	F14-UT-F14-F14-	44.7	25.9	31.8	34.9	18.3
1	F16-UT-F16-F16-	49.0	31.2	38.1	34.9	22.4
1 1/8	F18-UT-F18-F18-	55.1	31.2	46.0	42.9	24.6
1 1/4	F20-UT-F20-F20-	66.5	41.1	47.6	42.9	27.7
1 1/2	F24-UT-F24-F24-	78.0	50.0	57.2	50.8	34.0

Метрическая трубка

Трубка, мм	Артикул для заказа	Размеры, мм				
		L	C	G	F	E
2	M2-UT-M2-M2-	22.3	12.9	12	9.5	1.7
3	M3-UT-M3-M3-	22.3	12.9	12	9.5	2.4
4	M4-UT-M4-M4-	25.4	13.7	12	12.7	2.4
6	M6-UT-M6-M6-	27.0	15.3	14	12.7	4.8
8	M8-UT-M8-M8-	29.9	16.2	16	15.9	6.4
10	M10-UT-M10-M10-	31.5	17.2	19	17.5	7.9
12	M12-UT-M12-M12-	36.0	22.8	22	20.6	9.5
14	M14-UT-M14-M14-	38.8	24.4	25	25.4	11.1
15	M15-UT-M15-M15-	38.8	24.4	25	25.4	11.9
16	M16-UT-M16-M16-	38.8	24.4	25	25.4	12.7
18	M18-UT-M18-M18-	38.8	24.4	30	27.0	15.1
20	M20-UT-M20-M20-	44.6	26.0	32	34.9	15.9
22	M22-UT-M22-M22-	44.6	26.0	32	34.9	18.3
25	M25-UT-M25-M25-	49.1	31.3	38	34.9	21.8
28	M28-UT-M28-M28-	64.0	36.6	46	42.9	21.8
30	M30-UT-M30-M30-	69.9	39.6	50	42.9	26.2
32	M32-UT-M32-M32-	72.3	42.0	50	42.9	28.6
38	M38-UT-M38-M38-	84.0	49.4	60	50.8	33.7

Переходной соединительный тройник

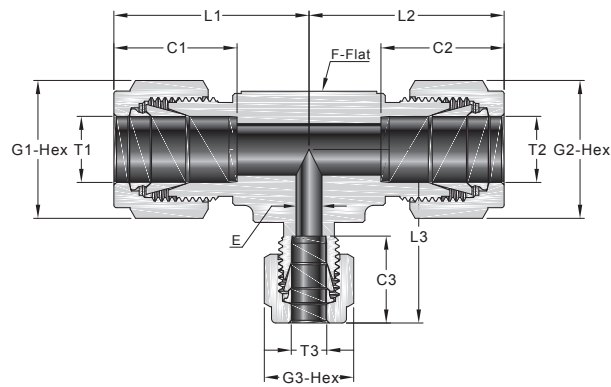

Двойная трубка

Т1- трубка, дюйм	Т2- трубка, дюйм	Т3- трубка, дюйм	Артикул для заказа	Размеры, мм										
				L1	L2	L3	C1	C2	C3	G1	G2	G3	F	E
1/4	1/4	1/8	F4-UT-F4-F2-	26.7	26.7	24.4	15.2	15.2	12.7	14.3	14.3	11.1	12.7	2.3
3/8	1/4	1/4	F6-UT-F4-F4-	30.5	29.0	29.0	16.8	15.2	15.2	17.5	14.3	14.3	15.9	4.8
3/8	1/4	3/8	F6-UT-F4-F6-	30.5	29.0	30.5	16.8	15.2	16.8	17.5	14.3	17.5	15.9	4.8
3/8	3/8	1/4	F6-UT-F6-F4-	30.5	30.5	29.0	16.8	16.8	15.2	17.5	17.5	14.3	15.9	4.8
1/2	1/4	1/4	F8-UT-F4-F4-	36.1	31.8	31.8	22.9	15.2	15.2	22.2	14.3	14.3	20.6	4.8
1/2	1/4	1/2	F8-UT-F4-F8-	36.1	31.8	36.1	22.9	15.2	22.9	22.2	14.3	22.2	20.6	4.8
1/2	3/8	3/8	F8-UT-F6-F6-	36.1	33.3	33.3	22.9	16.8	16.8	22.2	17.5	17.5	20.6	7.1
1/2	3/8	1/2	F8-UT-F6-F8-	36.1	33.3	36.1	22.9	16.8	22.9	22.2	17.5	22.2	20.6	7.1
1/2	1/2	1/4	F8-UT-F8-F4-	36.1	36.1	31.8	22.9	22.9	15.2	22.2	22.2	14.3	20.6	4.8
1/2	1/2	3/8	F8-UT-F8-F6-	36.1	36.1	33.3	22.9	22.9	16.8	22.2	22.2	17.5	20.6	7.1
5/8	3/8	3/8	F10-UT-F6-F6-	38.9	36.1	36.1	24.4	16.8	16.8	25.4	17.5	17.5	25.4	7.1
5/8	3/8	1/2	F10-UT-F6-F8-	38.9	36.1	38.9	24.4	16.8	22.9	25.4	17.5	22.2	25.4	7.1
5/8	1/2	3/8	F10-UT-F8-F6-	38.9	38.9	36.1	24.4	22.9	16.8	25.4	22.2	17.5	25.4	7.1
5/8	1/2	1/2	F10-UT-F8-F8-	38.9	38.9	38.9	24.4	22.9	22.9	25.4	22.2	22.2	25.4	10.4
5/8	5/8	3/8	F10-UT-F10-F6-	38.9	38.9	36.1	24.4	24.4	16.8	25.4	25.4	17.5	25.4	7.1
5/8	5/8	1/2	F10-UT-F10-F8-	38.9	38.9	38.9	24.4	24.4	22.9	25.4	25.4	22.2	25.4	10.4
3/4	3/8	3/8	F12-UT-F6-F6-	39.6	36.9	36.9	24.4	16.8	16.8	28.6	17.5	17.5	27.0	7.1
3/4	1/2	3/8	F12-UT-F8-F6-	39.6	39.6	36.9	24.4	22.9	16.8	28.6	22.2	17.5	27.0	7.1
3/4	1/2	1/2	F12-UT-F8-F8-	39.6	39.6	39.6	24.4	22.9	22.9	28.6	22.2	22.2	27.0	10.4
3/4	5/8	3/8	F12-UT-F10-F6-	39.6	39.6	36.9	24.4	24.4	16.8	28.6	25.4	17.5	27.0	7.1
3/4	5/8	1/2	F12-UT-F10-F8-	39.6	39.6	39.6	24.4	24.4	22.9	28.6	25.4	22.2	27.0	10.4
3/4	5/8	5/8	F12-UT-F10-F10-	39.6	39.6	39.6	24.4	24.4	24.4	28.6	25.4	25.4	27.0	12.7
3/4	3/4	1/4	F12-UT-F12-F4-	39.6	39.6	35.1	24.4	24.4	15.2	28.6	28.6	14.3	27.0	4.8
3/4	3/4	3/8	F12-UT-F12-F6-	39.6	39.6	36.9	24.4	24.4	16.8	28.6	28.6	17.5	27.0	7.1
3/4	3/4	1/2	F12-UT-F12-F8-	39.6	39.6	39.6	24.4	24.4	22.9	28.6	28.6	22.2	27.0	10.4
3/4	3/4	5/8	F12-UT-F12-F10-	39.6	39.6	39.6	24.4	24.4	24.4	28.6	28.6	25.4	27.0	12.7
7/8	1/2	3/4	F14-UT-F8-F12-	44.7	44.7	44.7	25.9	22.9	24.4	31.8	22.2	28.6	34.9	10.4
7/8	5/8	3/8	F14-UT-F10-F6-	44.7	44.7	41.9	25.9	24.4	16.8	31.8	25.4	17.5	34.9	7.1
7/8	3/4	3/8	F14-UT-F12-F6-	44.7	44.7	41.9	25.9	24.4	16.8	31.8	28.6	17.5	34.9	7.1
7/8	3/4	1/2	F14-UT-F12-F8-	44.7	44.7	44.7	25.9	24.4	22.9	31.8	28.6	22.2	34.9	10.4
7/8	3/4	3/4	F14-UT-F12-F12-	44.7	44.7	44.7	25.9	24.4	24.4	31.8	28.6	28.6	34.9	15.7
7/8	7/8	1/4	F14-UT-F14-F4-	44.7	44.7	40.4	25.9	25.9	15.2	31.8	31.8	14.3	34.9	4.8
7/8	7/8	3/8	F14-UT-F14-F6-	44.7	44.7	41.9	25.9	25.9	16.8	31.8	31.8	17.5	34.9	7.1
1	3/8	3/8	F16-UT-F6-F6-	49.3	41.9	41.9	31.2	16.8	16.8	38.1	17.5	17.5	34.9	7.1
1	1/2	1/4	F16-UT-F8-F4-	49.3	44.7	40.4	31.2	22.9	15.2	38.1	22.2	14.3	34.9	4.8
1	1/2	3/8	F16-UT-F8-F6-	49.3	44.7	41.9	31.2	22.9	16.8	38.1	22.2	17.5	34.9	7.1
1	1/2	1/2	F16-UT-F8-F8-	49.3	44.7	44.7	31.2	22.9	22.9	38.1	22.2	22.2	34.9	10.4
1	1/2	1	F16-UT-F8-F16-	49.3	44.7	49.3	31.2	22.9	31.2	38.1	22.2	38.1	34.9	10.4
1	5/8	3/8	F16-UT-F10-F6-	49.3	44.7	41.9	31.2	24.4	16.8	38.1	25.4	17.5	34.9	7.1
1	3/4	3/8	F16-UT-F12-F6-	49.3	44.7	41.9	31.2	24.4	16.8	38.1	28.6	17.5	34.9	7.1
1	3/4	1/2	F16-UT-F12-F8-	49.3	44.7	44.7	31.2	24.4	22.9	38.1	28.6	22.2	34.9	10.4
1	3/4	5/8	F16-UT-F12-F10-	49.3	44.7	44.7	31.2	24.4	24.4	38.1	28.6	25.4	34.9	12.7
1	3/4	1	F16-UT-F12-F16-	49.3	44.7	49.3	31.2	24.4	31.2	38.1	28.6	38.1	34.9	15.7
1	7/8	1/4	F16-UT-F14-F4-	49.3	44.7	40.4	31.2	25.9	15.2	38.1	31.8	14.3	34.9	4.8
1	7/8	3/8	F16-UT-F14-F6-	49.3	44.7	41.9	31.2	25.9	16.8	38.1	31.8	17.5	34.9	7.1
1	7/8	1/2	F16-UT-F14-F8-	49.3	44.7	44.7	31.2	25.9	22.9	38.1	31.8	22.2	34.9	10.4
1	7/8	3/4	F16-UT-F14-F12-	49.3	44.7	44.7	31.2	25.9	24.4	38.1	31.8	28.6	34.9	12.7
1	7/8	7/8	F16-UT-F14-F14-	49.3	44.7	44.7	31.2	25.9	25.9	38.1	31.8	31.8	34.9	18.3
1	1	1/4	F16-UT-F16-F4-	49.3	49.3	40.4	31.2	31.2	15.2	38.1	38.1	14.3	34.9	4.8
1	1	3/8	F16-UT-F16-F6-	49.3	49.3	41.9	31.2	31.2	16.8	38.1	38.1	17.5	34.9	7.1
1	1	1/2	F16-UT-F16-F8-	49.3	49.3	44.7	31.2	31.2	22.9	38.1	38.1	22.2	34.9	10.4
1	1	5/8	F16-UT-F16-F10-	49.3	49.3	44.7	31.2	31.2	24.4	38.1	38.1	25.4	34.9	12.7
1	1	3/4	F16-UT-F16-F12-	49.3	49.3	44.7	31.2	31.2	24.4	38.1	38.1	28.6	34.9	15.7
1	1	7/8	F16-UT-F16-F14-	49.3	49.3	44.7	31.2	31.2	25.9	38.1	38.1	31.8	34.9	18.3
1 1/4	1 1/4	1	F20-UT-F20-F16-	67.8	67.8	55.1	41.2	41.2	31.3	47.6	47.6	38.1	42.9	22.4
1 1/2	1 1/2	1	F24-UT-F24-F16-	78.7	78.7	60.0	50.0	50.0	31.3	57.2	57.2	38.1	50.8	22.4

Переходной соединительный тройник

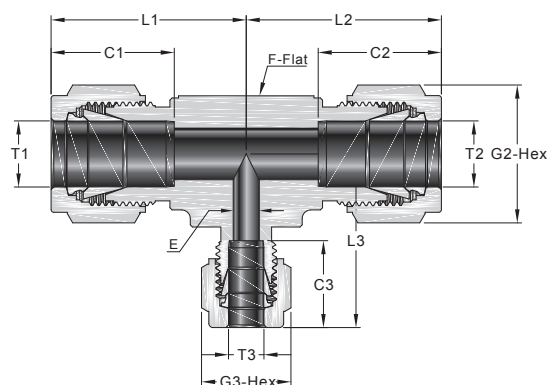

Метрическая трубка

T1- трубка, мм	T2- трубка, мм	T3- трубка, мм	Артикул для заказа	Размеры, мм										
				L1	L2	L3	C1	C2	C3	G1	G2	G3	F	E
3	3	6	M3-UT-M3-M6-	24.7	24.7	27.0	12.9	12.9	15.3	12	12	14	12.7	2.4
6	6	3	M6-UT-M6-M3-	27.0	27.0	25.4	15.3	15.3	12.9	14	14	12	12.7	2.4
6	6	8	M6-UT-M6-M8-	28.0	28.0	28.8	15.3	15.3	16.2	14	14	16	14.3	4.8
8	8	6	M8-UT-M8-M6-	30.0	30.0	29.0	16.2	16.2	15.3	16	16	14	15.9	4.8
8	8	12	M8-UT-M8-M12-	35.2	35.2	36.0	16.2	16.2	22.8	16	16	22	20.6	6.4
10	10	6	M10-UT-M10-M6-	31.5	31.5	29.9	17.2	17.2	15.3	19	19	14	17.5	4.8
10	10	8	M10-UT-M10-M8-	31.5	31.5	30.7	17.2	17.2	16.2	19	19	16	17.5	6.4
12	12	6	M12-UT-M12-M6-	36.0	36.0	31.8	22.8	22.8	15.3	22	22	14	20.6	4.8
12	12	8	M12-UT-M12-M8-	36.0	36.0	35.2	22.8	22.8	16.2	22	22	16	20.6	6.4
12	12	14	M12-UT-M12-M14-	38.0	38.0	38.0	22.8	22.8	24.4	22	22	25	25.4	9.5
12	12	18	M12-UT-M12-M18-	39.8	39.8	39.8	22.8	22.8	24.4	22	22	30	27.0	9.5
14	14	8	M14-UT-M14-M8-	38.0	38.0	37.2	24.4	24.4	16.2	25	25	16	25.4	6.4
14	14	10	M14-UT-M14-M10-	38.0	38.0	38.0	24.4	24.4	17.2	25	25	19	25.4	7.9
15	15	12	M15-UT-M15-M12-	38.8	38.8	38.8	24.4	24.4	22.8	25	25	22	25.4	9.5
16	16	8	M16-UT-M16-M8-	38.8	37.2	38.8	24.4	16.2	24.4	25	16	25	25.4	6.4
16	16	12	M16-UT-M16-M12-	38.8	38.8	38.9	24.4	24.4	22.8	25	25	22	25.4	9.5
18	18	8	M18-UT-M18-M8-	39.8	39.8	39.0	24.4	24.4	16.2	30	30	16	27.0	6.4
18	18	10	M18-UT-M18-M10-	39.8	39.8	39.8	24.4	24.4	17.2	30	30	19	27.0	7.9
18	18	12	M18-UT-M18-M12-	39.8	39.8	39.8	24.4	24.4	22.8	30	30	22	27.0	9.5
18	18	14	M18-UT-M18-M14-	39.8	39.8	39.8	24.4	24.4	24.4	30	30	25	27.0	11.1
20	20	14	M20-UT-M20-M14-	44.6	44.6	44.6	26.0	26.0	24.4	32	32	25	34.9	11.1
22	22	12	M22-UT-M22-M12-	44.6	44.6	44.6	26.0	26.0	22.8	32	32	22	34.9	9.5
25	25	12	M25-UT-M25-M12-	49.1	49.1	44.7	31.3	31.3	22.8	38	38	22	34.9	9.5

Соединительная крестовина

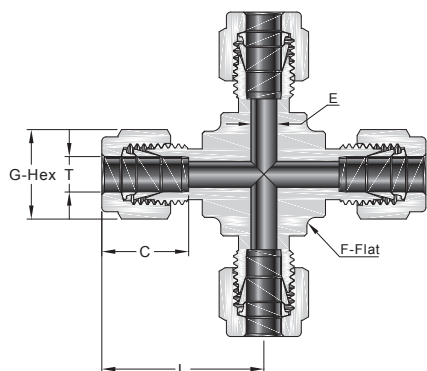

Дюймовая трубка

Трубка, дюйм	Артикул для заказа	Размеры, мм				
		L	C	G	F	E
1/8	F2-UC-F2-F2-F2-	22.4	12.7	11.1	9.5	2.3
3/16	F3-UC-F3-F3-F3-	24.4	13.7	12.7	11.1	3.0
1/4	F4-UC-F4-F4-F4-	26.9	15.2	14.3	12.7	4.8
5/16	F5-UC-F5-F5-F5-	29.7	16.2	15.9	15.9	6.4
3/8	F6-UC-F6-F6-F6-	30.5	16.8	17.5	15.9	7.1
1/2	F8-UC-F8-F8-F8-	36.1	22.9	22.2	20.6	10.4
5/8	F10-UC-F10-F10-F10-	36.3	24.4	25.4	27.0	12.7
3/4	F12-UC-F12-F12-F12-	39.9	24.4	28.6	27.0	15.7
7/8	F14-UC-F14-F14-F14-	44.7	25.9	31.8	34.9	18.3
1	F16-UC-F16-F16-F16-	49.0	31.2	38.1	34.9	22.4

Метрическая трубка

Трубка, мм	Артикул для заказа	Размеры, мм				
		L	C	G	F	E
3	M3-UC-M3-M3-M3-	22.3	12.9	12	9.5	2.4
4	M4-UC-M4-M4-M4-	25.4	13.7	12	12.7	2.4
6	M6-UC-M6-M6-M6-	27.0	15.3	14	12.7	4.8
8	M8-UC-M8-M8-M8-	29.9	16.2	16	15.9	6.4
10	M10-UC-M10-M10-M10-	33.5	17.2	19	20.6	7.9
12	M12-UC-M12-M12-M12-	36.0	22.8	22	20.6	9.5
16	M16-UC-M16-M16-M16-	37.0	24.4	25	23.8	12.7
18	M18-UC-M18-M18-M18-	38.3	24.4	30	27.0	15.1
20	M20-UC-M20-M20-M20-	44.6	26.0	32	34.9	15.9
22	M22-UC-M22-M22-M22-	44.7	26.0	32	34.9	18.3
25	M25-UC-M25-M25-M25-	49.2	31.3	38	34.9	21.8

Колпак

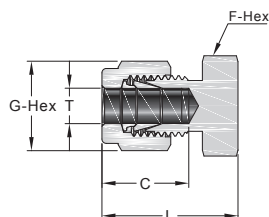

Дюймовая трубка

Трубка, дюйм	Артикул для заказа	Размеры, мм			
		L	C	G	F
1/16	CA-F1-	15.0	8.6	7.9	7.9
1/8	CA-F2-	20.1	12.7	11.1	11.1
3/16	CA-F3-	21.3	13.7	12.7	11.1
1/4	CA-F4-	23.4	15.2	14.3	12.7
5/16	CA-F5-	24.4	16.3	15.9	14.3
3/8	CA-F6-	25.7	16.8	17.5	15.9
1/2	CA-F8-	29.2	22.9	22.2	20.6
5/8	CA-F10-	30.0	24.4	25.4	23.8
3/4	CA-F12-	31.5	24.4	28.6	27.0
7/8	CA-F14-	34.0	25.9	31.8	30.2
1	CA-F16-	38.4	31.2	38.1	34.9
1 1/8	CA-F18-	38.4	31.2	46.0	41.3
1 1/4	CA-F20-	53.3	41.1	47.6	44.5
1 1/2	CA-F24-	64.5	50.0	57.2	54.0

Метрическая трубка

Трубка, мм	Артикул для заказа	Размеры, мм			
		L	C	G	F
2	CA-M2-	20.1	12.9	12	12
3	CA-M3-	20.1	12.9	12	12
4	CA-M4-	21.3	13.7	12	12
6	CA-M6-	23.1	15.3	14	14
8	CA-M8-	24.5	16.2	16	15
10	CA-M10-	26.6	17.2	19	18
12	CA-M12-	29.1	22.8	22	22
14	CA-M14-	29.9	24.4	25	24
15	CA-M15-	29.9	24.4	25	24
16	CA-M16-	29.9	24.4	25	24
18	CA-M18-	31.4	24.4	30	27
20	CA-M20-	34.0	26.0	32	30
22	CA-M22-	34.0	26.0	32	30
25	CA-M25-	38.5	31.3	38	35
28	CA-M28-	48.5	36.6	46	41
30	CA-M30-	53.4	39.6	50	46
32	CA-M32-	55.8	42.0	50	46
38	CA-M38-	65.4	49.4	60	55

Заглушка

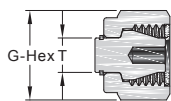

Дюймовая трубка

Трубка, дюйм	Артикул для заказа	Размеры, мм
		G
1/16	PL-F1-	7.9
1/8	PL-F2-	11.1
3/16	PL-F3-	12.7
1/4	PL-F4-	14.3
5/16	PL-F5-	15.9
3/8	PL-F6-	17.5
1/2	PL-F8-	22.2
5/8	PL-F10-	25.4
3/4	PL-F12-	28.6
7/8	PL-F14-	31.8
1	PL-F16-	38.1
1 1/4	PL-F20-	47.6
1 1/2	PL-F24-	57.2

Метрическая трубка

Трубка, мм	Артикул для заказа	Размеры, мм
		G
2	PL-M2-	12
3	PL-M3-	12
4	PL-M4-	12
6	PL-M6-	14
8	PL-M8-	16
10	PL-M10-	19
12	PL-M12-	22
14	PL-M14-	25
15	PL-M15-	25
16	PL-M16-	25
18	PL-M18-	30
20	PL-M20-	32
22	PL-M22-	32
25	PL-M25-	38
28	PL-M28-	46
30	PL-M30-	50
32	PL-M32-	50
38	PL-M38-	60

Переходники с трубным адаптером

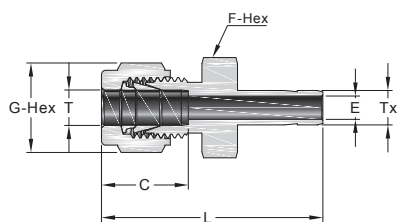

Дюймовая трубка

Т-Трубка, дюйм	Тх-Трубка, дюйм	Артикул для заказа	Размеры, мм				
			L	C	G	F	E
1/16	1/8	F1-R-FT2-	29.2	8.6	7.9	7.9	1.3
1/16	3/16	F1-R-FT3-	30.0	8.6	7.9	7.9	1.3
1/16	1/4	F1-R-FT4-	31.5	8.6	7.9	7.9	1.3
1/8	1/16	F2-R-FT1-	29.0	12.7	11.1	11.1	0.8
1/8	1/8	F2-R-FT2-	33.5	12.7	11.1	11.1	2.0
1/8	3/16	F2-R-FT3-	34.3	12.7	11.1	11.1	2.3
1/8	1/4	F2-R-FT4-	36.1	12.7	11.1	11.1	2.3
1/8	3/8	F2-R-FT6-	37.6	12.7	11.1	11.1	2.3
1/8	1/2	F2-R-FT8-	44.2	12.7	11.1	14.3	2.3
3/16	1/8	F3-R-FT2-	34.8	13.7	12.7	11.1	2.0
3/16	1/4	F3-R-FT4-	37.1	13.7	12.7	11.1	3.0
1/4	1/8	F4-R-FT2-	36.8	15.2	14.3	12.7	2.0
1/4	3/16	F4-R-FT3-	37.6	15.2	14.3	12.7	3.0
1/4	1/4	F4-R-FT4-	39.1	15.2	14.3	12.7	4.3
1/4	5/16	F4-R-FT5-	39.9	15.2	14.3	12.7	4.8
1/4	3/8	F4-R-FT6-	40.6	15.2	14.3	12.7	4.8
1/4	1/2	F4-R-FT8-	46.2	15.2	14.3	14.3	4.8
1/4	5/8	F4-R-FT10-	48.0	15.2	14.3	17.5	4.8
1/4	3/4	F4-R-FT12-	47.8	15.2	14.3	20.6	4.8
5/16	3/8	F5-R-FT6-	41.9	16.3	15.9	14.3	6.4
5/16	1/2	F5-R-FT8-	47.5	16.3	15.9	14.3	6.4
3/8	1/4	F6-R-FT4-	41.4	16.8	17.5	15.9	4.3
3/8	3/8	F6-R-FT6-	43.2	16.8	17.5	15.9	6.9
3/8	1/2	F6-R-FT8-	48.5	16.8	17.5	15.9	7.1
3/8	5/8	F6-R-FT10-	50.3	16.8	17.5	17.5	7.1
3/8	3/4	F6-R-FT12-	50.3	16.8	17.5	20.6	7.1
1/2	1/4	F8-R-FT4-	45.0	22.9	22.2	20.6	4.3
1/2	3/8	F8-R-FT6-	46.7	22.9	22.2	20.6	6.9
1/2	1/2	F8-R-FT8-	52.3	22.9	22.2	20.6	9.4
1/2	5/8	F8-R-FT10-	53.8	22.9	22.2	20.6	10.4
1/2	3/4	F8-R-FT12-	53.8	22.9	22.2	20.6	10.4
1/2	1	F8-R-FT16-	60.2	22.9	22.2	27.0	10.4
5/8	3/4	F10-R-FT12-	54.6	24.4	25.4	23.8	12.7
5/8	7/8	F10-R-FT14-	56.1	24.4	25.4	23.8	12.7
5/8	1	F10-R-FT16-	61.0	24.4	25.4	27.0	12.7
3/4	1/2	F12-R-FT8-	54.6	24.4	28.6	27.0	9.4
3/4	3/4	F12-R-FT12-	54.6	24.4	28.6	27.0	14.7
3/4	1	F12-R-FT16-	62.5	24.4	28.6	27.0	15.7

Дюймовая трубка

Т-Трубка, дюйм	Тх-Трубка, мм	Артикул для заказа	Размеры, мм				
			L	C	G	F	E
1/8	6	F2-R-MT6-	36.1	12.7	11.1	11.1	2.3

Метрическая трубка

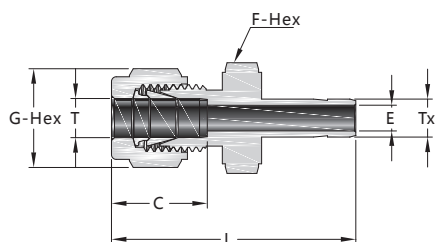

Т- Трубка, мм	Тх- Трубка, мм	Артикул для заказа	Размеры, мм				
			L	C	G	F	E
2	3	M2-R-MT3-	33.5	12.9	12	12	1.7
3	4	M3-R-MT4-	35.0	12.9	12	12	2.4
3	6	M3-R-MT6-	36.1	12.9	12	12	2.4
3	10	M3-R-MT10-	38.4	12.9	12	14	2.4
4	6	M4-R-MT6-	37.1	13.7	12	12	2.4
6	3	M6-R-MT3-	36.9	15.3	14	14	1.9
6	8	M6-R-MT8-	39.9	15.3	14	14	4.8
6	10	M6-R-MT10-	40.7	15.3	14	14	4.8
6	12	M6-R-MT12-	46.3	15.3	14	14	4.8
6	18	M6-R-MT18-	49.6	15.3	14	22	4.8
8	6	M8-R-MT6-	40.3	16.2	16	15	4.1
8	10	M8-R-MT10-	42.0	16.2	16	15	6.4
8	12	M8-R-MT12-	47.6	16.2	16	15	6.4
10	6	M10-R-MT6-	42.4	17.2	19	18	4.1
10	8	M10-R-MT8-	43.4	17.2	19	18	5.6
10	12	M10-R-MT12-	49.8	17.2	19	18	7.9
10	15	M10-R-MT15-	51.3	17.2	19	18	7.9
10	18	M10-R-MT18-	51.3	17.2	19	22	7.9
12	6	M12-R-MT6-	44.9	22.8	22	22	4.1
12	8	M12-R-MT8-	45.9	22.8	22	22	5.6
12	10	M12-R-MT10-	46.7	22.8	22	22	7.1
12	16	M12-R-MT16-	53.8	22.8	22	22	9.5
12	18	M12-R-MT18-	53.8	22.8	22	22	9.5
12	20	M12-R-MT20-	56.1	22.8	22	22	9.5
12	22	M12-R-MT22-	56.1	22.8	22	24	9.5
12	25	M12-R-MT25-	62.4	22.8	22	27	9.5
16	12	M16-R-MT12-	53.0	24.4	25	24	8.8
18	12	M18-R-MT12-	54.6	24.4	30	27	8.8
18	16	M18-R-MT16-	56.1	24.4	30	27	12.0
18	20	M18-R-MT20-	57.6	24.4	30	27	15.1
18	22	M18-R-MT22-	57.6	24.4	30	27	15.1
18	25	M18-R-MT25-	62.4	24.4	30	27	15.1
20	16	M20-R-MT16-	57.9	26.0	32	30	12.0
20	18	M20-R-MT18-	57.9	26.0	32	30	13.9
20	22	M20-R-MT22-	59.4	26.0	32	30	15.9
20	25	M20-R-MT25-	64.2	26.0	32	30	15.8
22	18	M22-R-MT18-	57.9	26.0	32	30	13.9
22	20	M22-R-MT20-	59.4	26.0	32	30	15.5
22	25	M22-R-MT25-	64.2	26.0	32	30	18.3
25	18	M25-R-MT18-	63.1	31.3	38	35	13.9
25	20	M25-R-MT20-	64.6	31.3	38	35	15.5

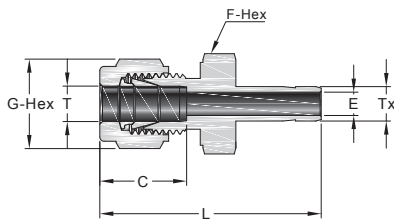

Метрическая трубка

Дюймовая трубка

Т-Трубка, мм	Тх-Трубка, дюйм	Артикул для заказа	Размеры, мм				
			L	C	G	F	E
2	1/8	M2-R-FT2-	33.5	12.9	12	12	1.7
3	1/8	M3-R-FT2-	33.5	12.9	12	12	2.0
3	1/4	M3-R-FT4-	36.1	12.9	12	12	2.4
4	1/4	M4-R-FT4-	37.1	13.7	12	12	2.4
6	1/8	M6-R-FT2-	36.9	15.3	14	14	2.0
6	1/4	M6-R-FT4-	39.2	15.3	14	14	4.4
6	5/16	M6-R-FT5-	39.9	15.3	14	14	4.8
6	3/8	M6-R-FT6-	40.7	15.3	14	14	4.8
6	1/2	M6-R-FT8-	46.3	15.3	14	14	4.8
8	1/4	M8-R-FT4-	40.3	16.2	16	15	4.4
8	3/8	M8-R-FT6-	42.0	16.2	16	15	6.4
8	1/2	M8-R-FT8-	47.6	16.2	16	15	6.4
10	3/8	M10-R-FT6-	44.2	17.2	19	18	6.8
10	1/2	M10-R-FT8-	49.8	17.2	19	18	7.9
12	1/2	M12-R-FT8-	52.3	22.8	22	22	9.3
12	3/4	M12-R-FT12-	53.8	22.8	22	22	9.5
18	3/4	M18-R-FT12-	56.1	24.4	30	27	14.7
18	1	M18-R-FT16-	62.4	24.4	30	27	15.1
25	1	M25-R-FT16-	69.5	31.3	38	35	20.2

Соединитель для фитингов

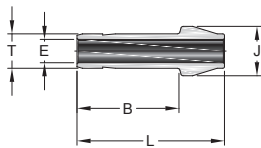

1" /25 мм и меньше

Дюймовая трубка

Трубка, дюйм	Артикул для заказа	Размеры, мм			
		L	B	E	J
1/16	PC-F1-	13.7	10.7	0.8	3.3
1/8	PC-F2-	22.4	15.7	2.0	6.1
1/4	PC-F4-	24.6	18.8	4.3	9.4
5/16	PC-F5-	25.9	20.1	5.6	10.9
3/8	PC-F6-	26.2	20.3	6.9	12.7
1/2	PC-F8-	35.8	25.9	9.4	15.7
5/8	PC-F10-	37.8	28.1	11.9	20.5
3/4	PC-F12-	37.3	27.7	14.7	22.1
1	PC-F16-	48.0	34.5	20.3	28.4
1 1/4	PC-F20- ^①	69.1	50.6	25.9	37.4
1 1/2	PC-F24- ^①	84.1	59.4	31.8	45.8

① Оснащен гайкой и предварительно обжатыми кольцами.

Метрическая трубка

Трубка, мм	Артикул для заказа	Размеры, мм			
		L	B	E	J
3	PC-M3-	22.2	15.7	1.9	6.0
6	PC-M6-	24.6	18.7	4.1	9.0
8	PC-M8-	25.9	20.0	5.6	11.0
10	PC-M10-	26.1	20.2	7.1	13.1
12	PC-M12-	35.8	26.0	8.8	15.0
15	PC-M15-	37.8	27.6	11.2	19.6
16	PC-M16-	37.8	27.6	12.0	20.6
18	PC-M18-	37.8	27.7	13.9	21.0
20	PC-M20-	39.4	29.2	15.5	24.6
25	PC-M25-	49.3	34.5	19.9	31.2
28	PC-M28- ^①	63.5	48.3	22.5	34.4
30	PC-M30- ^①	67.6	52.2	24.3	37.4
32	PC-M32- ^①	69.7	52.4	26.5	39.4
38	PC-M38- ^①	81.9	61.4	31.6	45.8

① Оснащен гайкой и предварительно обжатыми кольцами.



1 1/4" /28 мм и больше

Переходной соединитель для фитингов

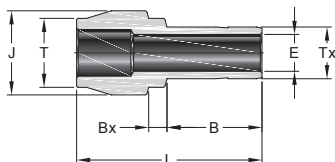

Дюймовая трубка

Т-Трубка, дюйм	Тх-Трубка, дюйм	Артикул для заказа	Размеры, мм				
			L	B	E	Bx	J
1/8	1/16	F2-PC-F1-	17.3	8.6	0.8	2.0	6.1
1/4	1/16	F4-PC-F1-	18.0	8.6	0.8	3.6	9.4
1/4	1/8	F4-PC-F2-	22.6	13.5	2.0	3.3	9.4
3/8	1/8	F6-PC-F2-	23.1	13.5	2.0	3.8	12.7
3/8	1/4	F6-PC-F4-	24.9	15.7	4.3	3.3	12.7
1/2	1/4	F8-PC-F4-	29.2	15.7	4.3	3.8	15.7
1/2	3/8	F8-PC-F6-	30.5	17.5	6.9	3.3	15.7
3/4	1/2	F12-PC-F8-	37.8	23.1	9.4	3.8	22.1
1	1/2	F16-PC-F8-	42.9	24.4	9.4	4.8	28.5
1	3/4	F16-PC-F12-	43.7	25.9	14.7	4.1	28.5

Метрическая трубка

Т-Трубка, мм	Тх-Трубка, мм	Артикул для заказа	Размеры, мм				
			L	B	E	Bx	J
6	3	M6-PC-M3-	22.6	13.5	1.9	3.2	9.0
8	6	M8-PC-M6-	24.7	15.7	4.1	3.1	11.0
10	6	M10-PC-M6-	25.0	15.7	4.1	3.4	13.1
10	8	M10-PC-M8-	26.3	17.0	5.6	3.1	13.1
12	6	M12-PC-M6-	29.6	15.7	4.1	3.6	15.0
12	8	M12-PC-M8-	29.8	16.8	5.6	3.4	15.0
12	10	M12-PC-M10-	30.4	17.5	7.1	3.1	15.0
16	12	M16-PC-M12-	36.2	23.1	8.8	3.4	19.0
28	25	M28-PC-M25-	56.5	33.0	19.8	8.2	34.3
32	25	M32-PC-M25-	60.3	33.0	19.8	9.9	39.5
38	25	M38-PC-M25-	65.8	33.0	19.8	12.3	47.1

Трубный адаптер с внешней резьбой

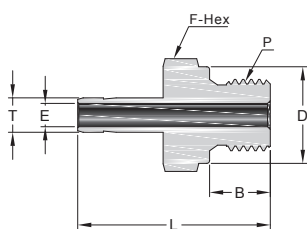

Дюймовая трубка

Цилиндрическая резьба ISO (BS)

Трубка, дюйм	P-BS Резьба	Артикул для заказа	Размеры, дюйм (мм)				
			L	B	E	F	D
1/8	1/8	FT2-MA-MBS2-	1.22(31.0)	0.28(7.1)	0.08(2.0)	0.56(14.3)	0.54(13.7)
1/8	1/4	FT2-MA-MBS4-	1.41(35.8)	0.44(11.2)	0.08(2.0)	0.75(19.1)	0.70(17.8)
1/4	1/8	FT4-MA-MBS2-	1.31(33.3)	0.28(7.1)	0.16(4.1)	0.56(14.3)	0.54(13.7)
1/4	1/4	FT4-MA-MBS4-	1.50(38.1)	0.44(11.2)	0.17(4.3)	0.75(19.1)	0.70(17.8)
3/8	1/8	FT6-MA-MBS2-	1.34(34.0)	0.28(7.1)	0.05(1.3)	0.56(14.3)	0.54(13.7)
3/8	1/4	FT6-MA-MBS4-	1.57(39.9)	0.44(11.2)	0.23(5.8)	0.75(19.1)	0.70(17.8)
3/8	3/8	FT6-MA-MBS6-	1.60(40.6)	0.44(11.2)	0.27(6.9)	0.87(22.2)	0.85(21.6)
3/8	1/2	FT6-MA-MBS8-	1.69(42.9)	0.56(14.2)	0.28(7.1)	1.06(27.0)	1.02(25.9)
1/2	1/4	FT8-MA-MBS4-	1.79(45.5)	0.44(11.2)	0.23(5.8)	0.75(19.1)	0.70(17.8)
1/2	3/8	FT8-MA-MBS6-	1.82(46.2)	0.44(11.2)	0.31(7.9)	0.87(22.2)	0.85(21.6)
1/2	1/2	FT8-MA-MBS8-	1.94(49.2)	0.56(14.2)	0.37(9.4)	1.06(27.0)	1.02(25.9)
5/8	1/2	FT10-MA-MBS8-	1.97(50.0)	0.56(14.2)	0.47(11.9)	1.06(27.0)	1.02(25.9)
3/4	3/4	FT12-MA-MBS12-	2.16(54.9)	0.63(16.0)	0.58(14.7)	1.31(33.3)	1.26(32.0)
1	1	FT16-MA-MBS16-	2.54(64.5)	0.72(18.3)	0.80(20.3)	1.63(41.3)	1.53(38.9)

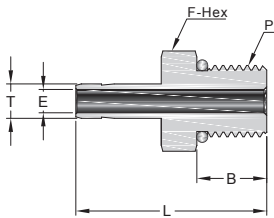
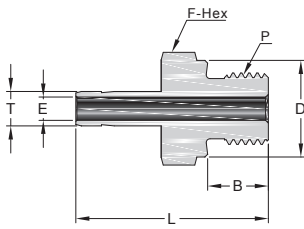

1" и меньше

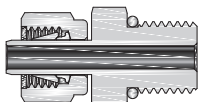

1 1/4" и больше

Адаптер по стандартам SAE J1926-1, ISO 11926-1 и MS 16142.

Трубный адаптер с внешней резьбой

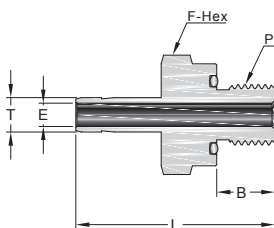
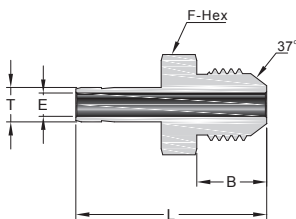

Дюймовая трубка

Цилиндрическая резьба ISO (BP)

Трубка, дюйм	P-ВР Резьба	Артикул для заказа	Размеры, дюйм (мм)				
			L	B	E	F	D
1/8	1/8	FT2-MA-PMBP2-	1.09(27.7)	0.28(7.1)	0.05(1.3)	0.56(14.3)	0.54(13.7)
1/8	1/4	FT2-MA-PMBP4-	1.31(33.3)	0.44(11.2)	0.05(1.3)	0.75(19.1)	0.70(17.8)
1/4	1/8	FT4-MA-PMBP2-	1.19(30.2)	0.28(7.1)	0.16(4.1)	0.56(14.3)	0.54(13.7)
1/4	1/4	FT4-MA-PMBP4-	1.50(38.1)	0.44(11.2)	0.18(4.6)	0.75(19.1)	0.70(17.8)
3/8	1/8	FT6-MA-PMBP2-	1.34(34.0)	0.28(7.1)	0.05(1.3)	0.75(19.1)	0.54(13.7)
3/8	1/4	FT6-MA-PMBP4-	1.47(37.3)	0.44(11.2)	0.25(6.4)	0.75(19.1)	0.70(17.8)
3/8	3/8	FT6-MA-PMBP6-	1.50(38.1)	0.44(11.2)	0.28(7.1)	0.87(22.2)	0.85(21.6)
3/8	1/2	FT6-MA-PMBP8-	1.69(42.9)	0.56(14.2)	0.28(7.1)	1.06(27.0)	1.02(25.9)
1/2	1/4	FT8-MA-PMBP4-	1.69(42.9)	0.44(11.2)	0.25(6.4)	0.75(19.1)	0.70(17.8)
1/2	3/8	FT8-MA-PMBP6-	1.72(43.7)	0.44(11.2)	0.31(7.9)	0.87(22.2)	0.85(21.6)
1/2	1/2	FT8-MA-PMBP8-	1.94(49.3)	0.56(14.2)	0.39(9.9)	1.06(27.0)	1.02(25.9)
5/8	1/2	FT10-MA-PMBP8-	1.97(50.0)	0.56(14.2)	0.47(11.9)	1.06(27.0)	1.02(25.9)
3/4	3/4	FT12-MA-PMBP12-	2.09(53.1)	0.63(16.0)	0.58(14.7)	1.32(33.5)	1.26(32.0)
1	1	FT16-MA-PMBP16-	2.49(63.3)	0.72(18.3)	0.80(20.3)	1.63(41.3)	1.53(38.9)

Дюймовая трубка

Прямая резьба SAE/MS

Трубка, дюйм	P-SAE/MS Резьба	Артикул для заказа	Размеры, дюйм (мм)			
			L	B	E	F
1/8	5/16-24	FT2-MA-OST5-	1.20(30.5)	0.30(7.6)	0.08(2.0)	0.44(11.1)
1/4	7/16-20	FT4-MA-OST7-	1.39(35.3)	0.36(9.1)	0.17(4.3)	0.56(14.3)
3/8	7/16-20	FT6-MA-OST7-	1.46(37.1)	0.36(9.1)	0.20(5.1)	0.56(14.3)
3/8	9/16-18	FT6-MA-OST9-	1.52(38.6)	0.39(9.9)	0.27(6.9)	0.69(17.5)
3/8	3/4-16	FT6-MA-OST12-	1.60(40.6)	0.44(11.2)	0.27(6.9)	0.87(22.2)
1/2	9/16-18	FT8-MA-OST9-	1.74(44.2)	0.39(9.9)	0.28(7.1)	0.69(17.5)
1/2	3/4-16	FT8-MA-OST12-	1.82(46.2)	0.44(11.2)	0.37(9.4)	0.87(22.2)
5/8	7/8-14	FT10-MA-OST14-	1.94(49.3)	0.50(12.7)	0.47(11.9)	1.00(25.4)
3/4	1 1/16-12	FT12-MA-OST17-	2.10(53.3)	0.59(15.0)	0.58(14.7)	1.25(31.8)
1	1 5/16-12	FT16-MA-OST21-	2.41(61.2)	0.59(15.0)	0.80(20.3)	1.50(38.1)
1 1/4	1 5/8-12	FT20-MA-OST26- [®]	2.81(71.4)	0.59(15.0)	1.02(25.9)	1.87(47.6)
1 1/2	1 7/8-12	FT24-MA-OST30- [®]	3.28(83.3)	0.59(15.0)	1.25(31.8)	2.13(54.0)

① Оснащен гайкой и предварительно обжатыми кольцами.

Дюймовая трубка

AN резьба 37°

Трубка, дюйм	Размер резьбы AN	Артикул для заказа	Размеры, дюйм (мм)			
			L	B	E	F
1/4	1/4	FT4-MA-AN4-	1.46(37.1)	0.55(14.0)	0.17(4.3)	0.50(12.7)
3/8	1/4	FT6-MA-AN4-	1.53(38.9)	0.55(14.0)	0.17(4.3)	0.50(12.7)
3/8	3/8	FT6-MA-AN6-	1.56(39.6)	0.56(14.2)	0.27(6.9)	0.63(15.9)
1/2	1/2	FT8-MA-AN8-	1.91(48.5)	0.66(16.8)	0.37(9.4)	0.81(20.6)
3/4	3/4	FT12-MA-AN12-	2.21(56.1)	0.86(21.8)	0.58(14.7)	1.13(28.6)
1	1	FT16-MA-AN16-	2.58(65.5)	0.91(23.1)	0.80(20.3)	1.37(34.9)

Дюймовая трубка

Прямая резьба SAE/MS с уплотнением

Трубка, дюйм	P-SAE/MS Резьба	Артикул для заказа	Размеры, дюйм (мм)			
			L	B	E	F
1/8	5/16-24	FT2-MA-STO5-	1.28(32.5)	0.34(8.6)	0.08(2.0)	0.56(14.3)
3/16	3/8-24	FT3-MA-STO6-	1.38(35.1)	0.38(9.7)	0.12(3.0)	0.63(15.9)
1/4	7/16-20	FT4-MA-STO7-	1.54(39.1)	0.41(10.4)	0.17(4.3)	0.75(19.1)
5/16	1/2-20	FT5-MA-STO8-	1.64(41.7)	0.44(11.2)	0.22(5.6)	0.87(22.2)
3/8	9/16-18	FT6-MA-STO9-	1.70(43.2)	0.47(11.9)	0.27(6.9)	0.94(23.8)
1/2	3/4-16	FT8-MA-STO12-	1.95(49.5)	0.47(11.9)	0.37(9.4)	1.13(28.6)

Трубный адаптер с внешней резьбой

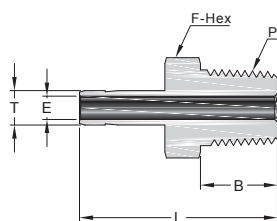

1" и меньше

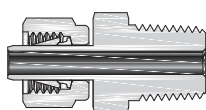

1 1/4" и больше

Дюймовая трубка

Резьба NPT

Трубка, дюйм	P-NPT Резьба	Артикул для заказа	Размеры, дюйм (мм)			
			L	B	E	F
1/16	1/8	FT1-MA-NPT2-	1.00(25.4)	0.38(9.7)	0.03(0.8)	0.44(11.1)
1/8	1/8	FT2-MA-NPT2-	1.16(29.5)	0.38(9.7)	0.08(2.0)	0.44(11.1)
1/8	1/4	FT2-MA-NPT4-	1.37(34.8)	0.56(14.2)	0.08(2.0)	0.56(14.3)
3/16	1/8	FT3-MA-NPT2-	1.19(30.2)	0.38(9.7)	0.12(3.0)	0.44(11.1)
3/16	1/4	FT3-MA-NPT4-	1.40(35.6)	0.56(14.2)	0.12(3.0)	0.56(14.3)
1/4	1/8	FT4-MA-NPT2-	1.25(31.8)	0.38(9.7)	0.17(4.3)	0.44(11.1)
1/4	1/4	FT4-MA-NPT4-	1.46(37.1)	0.56(14.2)	0.17(4.3)	0.56(14.3)
1/4	3/8	FT4-MA-NPT6-	1.49(37.8)	0.56(14.2)	0.17(4.3)	0.69(17.5)
1/4	1/2	FT4-MA-NPT8-	1.71(43.4)	0.75(19.1)	0.17(4.3)	0.87(22.2)
5/16	1/8	FT5-MA-NPT2-	1.29(32.8)	0.38(9.7)	0.19(4.8)	0.44(11.1)
5/16	1/4	FT5-MA-NPT4-	1.50(38.1)	0.56(14.2)	0.22(5.6)	0.56(14.3)
5/16	3/8	FT5-MA-NPT6-	1.53(38.9)	0.56(14.2)	0.22(5.6)	0.69(17.5)
5/16	1/2	FT5-MA-NPT8-	1.74(44.2)	0.75(19.1)	0.22(5.6)	0.87(22.2)
3/8	1/8	FT6-MA-NPT2-	1.32(33.5)	0.38(9.7)	0.19(4.8)	0.44(11.1)
3/8	1/4	FT6-MA-NPT4-	1.53(38.9)	0.56(14.2)	0.27(6.9)	0.56(14.3)
3/8	3/8	FT6-MA-NPT6-	1.56(39.6)	0.56(14.2)	0.27(6.9)	0.69(17.5)
3/8	1/2	FT6-MA-NPT8-	1.78(45.2)	0.75(19.1)	0.27(6.9)	0.87(22.2)
1/2	1/4	FT8-MA-NPT4-	1.75(44.5)	0.56(14.2)	0.28(7.1)	0.56(14.3)
1/2	3/8	FT8-MA-NPT6-	1.78(45.2)	0.56(14.2)	0.37(9.4)	0.69(17.5)
1/2	1/2	FT8-MA-NPT8-	2.00(50.8)	0.75(19.1)	0.37(9.4)	0.87(22.2)
5/8	1/2	FT10-MA-NPT8-	2.06(52.3)	0.75(19.1)	0.47(11.9)	0.87(22.2)
3/4	1/2	FT12-MA-NPT8-	2.06(52.3)	0.75(19.1)	0.47(11.9)	0.87(22.2)
3/4	3/4	FT12-MA-NPT12-	2.06(52.3)	0.75(19.1)	0.58(14.7)	1.06(27.0)
3/4	1	FT12-MA-NPT16-	2.41(61.2)	0.94(23.9)	0.81(20.7)	1.37(34.9)
1	3/4	FT16-MA-NPT12-	2.31(58.7)	0.75(19.1)	0.62(15.7)	1.06(27.0)
1	1	FT16-MA-NPT16-	2.60(66.0)	0.94(23.9)	0.80(20.3)	1.37(34.9)
1 1/4	1 1/4	FT20-MA-NPT20- [Ⓢ]	3.16(80.3)	0.94(23.9)	1.02(25.9)	1.75(44.5)
1 1/2	1 1/2	FT24-MA-NPT24- [Ⓢ]	3.72(94.5)	1.03(26.2)	1.25(31.8)	2.13(54.0)

Ⓢ Оснащен гайкой и предварительно обжатými кольцами.

Дюймовая трубка

Коническая резьба ISO (BSPT)

Трубка, дюйм	P-BSPT Резьба	Артикул для заказа	Размеры, дюйм (мм)			
			L	B	E	F
1/8	1/8	FT2-MA-MBT2-	1.16(29.5)	0.38(9.7)	0.08(2.0)	0.44(11.1)
1/8	1/4	FT2-MA-MBT4-	1.37(34.8)	0.56(14.2)	0.08(2.0)	0.56(14.3)
1/4	1/8	FT4-MA-MBT2-	1.25(31.8)	0.38(9.7)	0.17(4.3)	0.44(11.1)
1/4	1/4	FT4-MA-MBT4-	1.46(37.1)	0.56(14.2)	0.17(4.3)	0.56(14.3)
1/4	3/8	FT4-MA-MBT6-	1.49(37.8)	0.56(14.2)	0.17(4.3)	0.69(17.5)
1/4	1/2	FT4-MA-MBT8-	1.71(43.4)	0.75(19.1)	0.17(4.3)	0.87(22.2)
5/16	1/8	FT5-MA-MBT2-	1.29(32.8)	0.38(9.7)	0.19(4.8)	0.44(11.1)
5/16	1/4	FT5-MA-MBT4-	1.50(38.1)	0.56(14.2)	0.22(5.6)	0.56(14.3)
3/8	1/4	FT6-MA-MBT4-	1.53(38.9)	0.56(14.2)	0.27(6.9)	0.56(14.3)
3/8	3/8	FT6-MA-MBT6-	1.56(39.6)	0.56(14.2)	0.27(6.9)	0.69(17.5)
3/8	1/2	FT6-MA-MBT8-	1.78(45.2)	0.75(19.1)	0.27(6.9)	0.87(22.2)
1/2	1/4	FT8-MA-MBT4-	1.75(44.5)	0.56(14.2)	0.28(7.1)	0.56(14.3)
1/2	3/8	FT8-MA-MBT6-	1.78(45.2)	0.56(14.2)	0.37(9.4)	0.69(17.5)
1/2	1/2	FT8-MA-MBT8-	2.00(50.8)	0.75(19.1)	0.37(9.4)	0.87(22.2)
5/8	3/8	FT10-MA-MBT6-	1.91(48.5)	0.56(14.2)	0.37(9.5)	0.69(17.5)
5/8	1/2	FT10-MA-MBT8-	2.06(52.3)	0.75(19.1)	0.47(11.9)	0.87(22.2)
3/4	3/4	FT12-MA-MBT12-	2.06(52.3)	0.75(19.1)	0.58(14.7)	1.06(27.0)
1	1	FT16-MA-MBT16-	2.60(66.0)	0.94(23.9)	0.80(20.3)	1.37(34.9)

Трубный адаптер с внешней резьбой

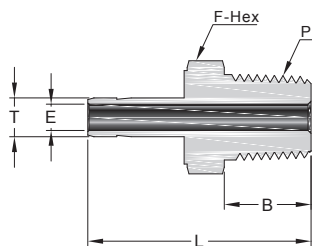

25 мм и меньше

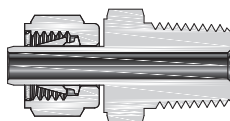

28 мм и больше

Метрическая трубка

Резьба NPT

Трубка, мм	P-NPT резьба	Артикул для заказа	Размеры, дюйм (мм)			
			L	B	E	F
3	1/8	MT3-MA-NPT2-	29.4(1.16)	9.7(0.38)	1.8(0.07)	12.0(0.47)
4	1/8	MT4-MA-NPT2-	29.4(1.16)	9.7(0.38)	2.0(0.08)	12.0(0.47)
6	1/8	MT6-MA-NPT2-	32.8(1.29)	9.7(0.38)	4.1(0.16)	12.0(0.47)
6	1/4	MT6-MA-NPT4-	38.1(1.50)	14.2(0.56)	4.1(0.16)	14.0(0.55)
6	3/8	MT6-MA-NPT6-	39.2(1.54)	14.2(0.56)	4.1(0.16)	18.0(0.71)
6	1/2	MT6-MA-NPT8-	42.1(1.66)	19.1(0.75)	4.1(0.16)	22.0(0.87)
8	1/4	MT8-MA-NPT4-	39.1(1.54)	14.2(0.56)	5.6(0.22)	14.0(0.55)
8	3/8	MT8-MA-NPT6-	39.9(1.57)	14.2(0.56)	5.6(0.22)	19.0(0.75)
10	1/4	MT10-MA-NPT4-	39.9(1.57)	14.2(0.56)	7.1(0.28)	14.0(0.55)
10	3/8	MT10-MA-NPT6-	40.6(1.60)	14.2(0.56)	7.1(0.28)	18.0(0.71)
10	1/2	MT10-MA-NPT8-	46.2(1.82)	19.1(0.75)	7.1(0.28)	22.0(0.87)
12	1/4	MT12-MA-NPT4-	46.5(1.83)	14.2(0.56)	7.1(0.28)	14.0(0.55)
12	3/8	MT12-MA-NPT6-	46.2(1.82)	14.2(0.56)	8.8(0.35)	18.0(0.71)
12	1/2	MT12-MA-NPT8-	52.1(2.05)	19.1(0.75)	8.8(0.35)	22.0(0.87)
16	1/2	MT16-MA-NPT8-	50.8(2.00)	19.1(0.75)	12.7(0.50)	22.0(0.87)
16	3/4	MT16-MA-NPT12-	51.6(2.03)	19.1(0.75)	12.7(0.50)	27.0(1.06)
18	1/2	MT18-MA-NPT8-	50.8(2.00)	19.1(0.75)	12.7(0.50)	27.0(1.06)
18	3/4	MT18-MA-NPT12-	51.6(2.03)	19.1(0.75)	14.0(0.55)	27.0(1.06)
20	1/2	MT20-MA-NPT8-	51.8(2.04)	19.1(0.75)	11.9(0.47)	22.0(0.87)
20	3/4	MT20-MA-NPT12-	52.4(2.06)	19.1(0.75)	15.1(0.59)	27.0(1.06)
25	1	MT25-MA-NPT16-	65.9(2.59)	23.9(0.94)	19.8(0.78)	35.0(1.38)
28	1	MT28-MA-NPT16- ^①	74.4(2.93)	23.9(0.94)	22.2(0.87)	35.0(1.38)
28	1 1/4	MT28-MA-NPT20- ^①	76.2(3.00)	23.9(0.94)	22.5(0.89)	46.0(1.81)
30	1	MT30-MA-NPT16- ^①	79.2(3.12)	23.9(0.94)	22.2(0.87)	41.0(1.61)
30	1 1/4	MT30-MA-NPT20- ^①	80.0(3.15)	23.9(0.94)	24.3(0.96)	46.0(1.81)
32	1 1/4	MT32-MA-NPT20- ^①	81.0(3.19)	23.9(0.94)	26.5(1.04)	46.0(1.81)
38	1 1/2	MT38-MA-NPT24- ^①	92.2(3.63)	26.2(1.03)	31.6(1.24)	55.0(2.17)

① Оснащен гайкой и предварительно обжатými кольцами.

Метрическая трубка

Коническая резьба ISO (BSPT)

Трубка, мм	P-BSPT Резьба	Артикул для заказа	Размеры, дюйм (мм)			
			L	B	E	F
3	1/8	MT3-MA-MBT2-	29.4(1.16)	9.7(0.38)	1.8(0.07)	12.0(0.47)
4	1/8	MT4-MA-MBT2-	29.4(1.16)	9.7(0.38)	2.0(0.08)	12.0(0.47)
6	1/8	MT6-MA-MBT2-	32.8(1.29)	9.7(0.38)	4.1(0.16)	12.0(0.47)
6	1/4	MT6-MA-MBT4-	38.1(1.50)	14.2(0.56)	4.1(0.16)	14.0(0.55)
8	1/4	MT8-MA-MBT4-	39.1(1.54)	14.2(0.56)	5.6(0.22)	14.0(0.55)
8	3/8	MT8-MA-MBT6-	39.9(1.57)	14.2(0.56)	5.6(0.22)	18.0(0.71)
10	1/4	MT10-MA-MBT4-	39.9(1.57)	14.2(0.56)	7.1(0.28)	14.0(0.55)
10	3/8	MT10-MA-MBT6-	40.6(1.60)	14.2(0.56)	7.1(0.28)	18.0(0.71)
10	1/2	MT10-MA-MBT8-	44.5(1.75)	19.1(0.75)	7.5(0.30)	22.0(0.87)
12	1/4	MT12-MA-MBT4-	46.5(1.83)	14.2(0.56)	7.1(0.28)	16.0(0.63)
12	3/8	MT12-MA-MBT6-	46.2(1.82)	14.2(0.56)	8.8(0.35)	18.0(0.71)
12	1/2	MT12-MA-MBT8-	51.8(2.04)	19.1(0.75)	8.8(0.35)	22.0(0.87)
16	1/2	MT16-MA-MBT8-	50.8(2.00)	19.1(0.75)	12.7(0.50)	22.0(0.87)
18	3/4	MT18-MA-MBT12-	51.6(2.03)	19.1(0.75)	14.0(0.55)	27.0(1.06)
20	3/4	MT20-MA-MBT12-	52.4(2.06)	19.1(0.75)	15.1(0.59)	27.0(1.06)
25	1	MT25-MA-MBT16-	65.9(2.59)	23.9(0.94)	19.8(0.78)	35.0(1.38)
28	1	MT28-MA-MBT16- ^①	74.7(2.94)	23.9(0.94)	22.2(0.87)	35.0(1.38)
28	1 1/4	MT28-MA-MBT20- ^①	76.2(3.00)	23.9(0.94)	22.5(0.89)	46.0(1.81)
30	1 1/4	MT30-MA-MBT20- ^①	80.0(3.15)	23.9(0.94)	24.3(0.96)	46.0(1.81)
32	1 1/4	MT32-MA-MBT20- ^①	81.0(3.19)	23.9(0.94)	26.5(1.04)	46.0(1.81)
38	1 1/2	MT38-MA-MBT24- ^①	92.2(3.63)	26.2(1.03)	31.6(1.24)	55.0(2.17)

① Оснащен гайкой и предварительно обжатými кольцами.

Трубный адаптер с внешней резьбой

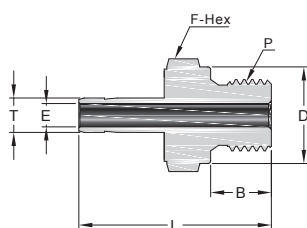

25 мм и меньше

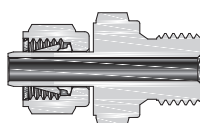

28 мм и больше

Метрическая трубка

Цилиндрическая резьба ISO (BS)

Трубка, мм	P-BS Резьба	Артикул для заказа	Размеры, дюйм (мм)				
			L	B	E	F	D
3	1/8	MT3-MA-MBS2-	31.0(1.22)	7.1(0.28)	1.8(0.07)	14.0(0.55)	13.7(0.54)
4	1/8	MT4-MA-MBS2-	31.8(1.25)	7.1(0.28)	2.0(0.08)	14.0(0.55)	13.7(0.54)
6	1/8	MT6-MA-MBS2-	34.3(1.35)	7.1(0.28)	4.0(0.16)	14.0(0.55)	13.7(0.54)
6	1/4	MT6-MA-MBS4-	39.1(1.54)	11.2(0.44)	4.1(0.16)	19.0(0.75)	17.8(0.70)
8	1/4	MT8-MA-MBS4-	40.1(1.58)	11.2(0.44)	5.6(0.22)	19.0(0.75)	17.8(0.70)
10	1/4	MT10-MA-MBS4-	40.9(1.61)	11.2(0.44)	5.9(0.23)	19.0(0.75)	17.8(0.70)
10	3/8	MT10-MA-MBS6-	41.7(1.64)	11.2(0.44)	7.1(0.28)	22.0(0.87)	21.6(0.85)
10	1/2	MT10-MA-MBS8-	44.7(1.76)	14.2(0.56)	7.1(0.28)	27.0(1.06)	25.9(1.02)
12	1/4	MT12-MA-MBS4-	46.7(1.84)	11.2(0.44)	5.9(0.23)	19.0(0.75)	17.8(0.70)
12	3/8	MT12-MA-MBS6-	47.2(1.86)	11.2(0.44)	7.9(0.31)	22.0(0.87)	21.6(0.85)
12	1/2	MT12-MA-MBS8-	50.5(1.99)	14.2(0.56)	8.8(0.35)	27.0(1.06)	25.9(1.02)
16	1/2	MT16-MA-MBS8-	50.8(2.00)	14.2(0.56)	11.9(0.47)	27.0(1.06)	25.9(1.02)
18	3/4	MT18-MA-MBS12-	55.9(2.20)	16.0(0.63)	13.9(0.55)	35.0(1.38)	32.0(1.26)
20	3/4	MT20-MA-MBS12-	57.0(2.24)	16.0(0.63)	15.1(0.59)	35.0(1.38)	32.0(1.26)
25	1	MT25-MA-MBS16-	65.1(2.56)	18.3(0.72)	19.8(0.78)	41.0(1.61)	38.9(1.53)
28	1	MT28-MA-MBS16- [Ⓢ]	72.9(2.87)	18.3(0.72)	19.8(0.78)	41.0(1.61)	38.9(1.53)
28	1 1/4	MT28-MA-MBS20- [Ⓢ]	77.0(3.03)	19.8(0.78)	22.5(0.89)	50.0(1.97)	49.0(1.93)
30	1 1/4	MT30-MA-MBS20- [Ⓢ]	80.8(3.18)	19.8(0.78)	24.3(0.96)	50.0(1.97)	49.0(1.93)
32	1 1/4	MT32-MA-MBS20- [Ⓢ]	81.8(3.22)	19.8(0.78)	26.5(1.04)	50.0(1.97)	49.0(1.93)
38	1 1/2	MT38-MA-MBS24- [Ⓢ]	94.5(3.72)	22.1(0.87)	31.6(1.24)	55.0(2.17)	54.7(2.15)

Ⓢ Оснащен гайкой и предварительно обжатыми кольцами.

Метрическая трубка

Цилиндрическая резьба ISO (BP)

Трубка, мм	P-BP Резьба	Артикул для заказа	Размеры, дюйм (мм)				
			L	B	E	F	D
3	1/8	MT3-MA-PMBP2-	31.0(1.22)	7.1(0.28)	1.8(0.07)	14.0(0.55)	13.7(0.54)
4	1/8	MT4-MA-PMBP2-	31.8(1.25)	7.1(0.28)	2.0(0.08)	14.0(0.55)	13.7(0.54)
6	1/8	MT6-MA-PMBP2-	33.3(1.31)	7.1(0.28)	4.0(0.16)	14.0(0.55)	13.7(0.54)
6	1/4	MT6-MA-PMBP4-	38.1(1.50)	11.2(0.44)	4.0(0.16)	19.0(0.75)	17.8(0.70)
8	1/4	MT8-MA-PMBP4-	38.9(1.53)	11.2(0.44)	6.4(0.25)	19.0(0.75)	17.8(0.70)
10	1/4	MT10-MA-PMBP4-	38.9(1.53)	11.2(0.44)	6.4(0.25)	19.0(0.75)	17.8(0.70)
10	3/8	MT10-MA-PMBP6-	39.7(1.56)	11.2(0.44)	7.5(0.30)	22.0(0.87)	21.6(0.85)
10	1/2	MT10-MA-PMBP8-	42.9(1.69)	14.2(0.56)	7.5(0.30)	27.0(1.06)	25.9(1.02)
12	1/4	MT12-MA-PMBP4-	43.7(1.72)	11.2(0.44)	6.4(0.25)	19.0(0.75)	17.8(0.70)
12	3/8	MT12-MA-PMBP6-	44.5(1.75)	11.2(0.44)	7.9(0.31)	22.0(0.87)	21.6(0.85)
12	1/2	MT12-MA-PMBP8-	49.2(1.94)	14.2(0.56)	9.1(0.36)	27.0(1.06)	25.9(1.02)
16	1/2	MT16-MA-PMBP8-	50.8(2.00)	14.2(0.56)	11.9(0.47)	27.0(1.06)	25.9(1.02)
18	3/4	MT18-MA-PMBP12-	53.2(2.09)	16.0(0.63)	14.0(0.55)	33.0(1.30)	32.0(1.26)
20	3/4	MT20-MA-PMBP12-	54.0(2.13)	16.0(0.63)	15.1(0.59)	33.0(1.30)	32.0(1.26)
25	1	MT25-MA-PMBP16-	65.1(2.56)	18.3(0.72)	19.8(0.78)	41.0(1.61)	38.9(1.53)
28	1	MT28-MA-PMBP16-	72.7(2.86)	18.3(0.72)	19.8(0.78)	41.0(1.61)	38.9(1.53)
28	1 1/4	MT28-MA-PMBP20- [Ⓢ]	77.3(3.04)	19.8(0.78)	22.5(0.89)	50.0(1.97)	49.0(1.93)
30	1 1/4	MT30-MA-PMBP20- [Ⓢ]	80.8(3.18)	19.8(0.78)	24.3(0.96)	50.0(1.97)	49.0(1.93)
32	1 1/4	MT32-MA-PMBP20- [Ⓢ]	82.1(3.23)	19.8(0.78)	26.5(1.04)	50.0(1.97)	49.0(1.93)
38	1 1/2	MT38-MA-PMBP24- [Ⓢ]	94.5(3.72)	22.1(0.87)	31.6(1.24)	55.0(2.17)	54.7(2.15)

Ⓢ Оснащен гайкой и предварительно обжатыми кольцами.

Трубный адаптер с внутренней резьбой

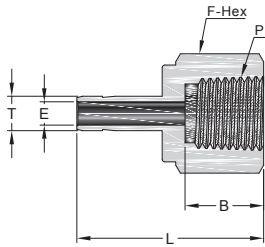

1" и меньше

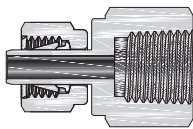

1 1/4" и больше

Дюймовая трубка

Резьба NPT

Трубка, дюйм	P-NPT резьба	Артикул для заказа	Размеры, дюйм (мм)			
			L	B	E	F
1/16	1/8	FT1-FA-FNPT2-	1.07(27.2)	0.41(10.4)	0.03(0.8)	0.56(14.3)
1/8	1/8	FT2-FA-FNPT2-	1.24(31.5)	0.41(10.4)	0.08(2.0)	0.56(14.3)
1/8	1/4	FT2-FA-FNPT4-	1.39(35.3)	0.59(15.0)	0.08(2.0)	0.75(19.1)
3/16	1/8	FT3-FA-FNPT2-	1.25(31.8)	0.41(10.4)	0.11(2.9)	0.56(14.3)
3/16	1/4	FT3-FA-FNPT4-	1.41(35.8)	0.59(15.0)	0.12(3.0)	0.75(19.1)
1/4	1/8	FT4-FA-FNPT2-	1.30(33.0)	0.41(10.4)	0.17(4.3)	0.56(14.3)
1/4	1/4	FT4-FA-FNPT4-	1.46(37.1)	0.59(15.0)	0.17(4.3)	0.75(19.1)
1/4	3/8	FT4-FA-FNPT6-	1.55(39.4)	0.59(15.0)	0.17(4.3)	0.87(22.2)
1/4	1/2	FT4-FA-FNPT8-	1.79(45.5)	0.78(19.8)	0.17(4.3)	1.06(27.0)
5/16	1/8	FT5-FA-FNPT2-	1.34(34.0)	0.41(10.4)	0.22(5.6)	0.56(14.3)
5/16	1/4	FT5-FA-FNPT4-	1.48(37.6)	0.59(15.0)	0.22(5.6)	0.75(19.1)
5/16	3/8	FT5-FA-FNPT6-	1.59(40.4)	0.59(15.0)	0.22(5.6)	0.87(22.2)
3/8	1/8	FT6-FA-FNPT2-	1.35(34.3)	0.41(10.4)	0.27(6.9)	0.56(14.3)
3/8	1/4	FT6-FA-FNPT4-	1.50(38.1)	0.59(15.0)	0.27(6.9)	0.75(19.1)
3/8	3/8	FT6-FA-FNPT6-	1.59(40.4)	0.59(15.0)	0.27(6.9)	0.87(22.2)
3/8	1/2	FT6-FA-FNPT8-	1.84(46.7)	0.78(19.8)	0.27(6.9)	1.06(27.0)
1/2	1/4	FT8-FA-FNPT4-	1.71(43.4)	0.59(15.0)	0.37(9.4)	0.75(19.1)
1/2	3/8	FT8-FA-FNPT6-	1.79(45.5)	0.59(15.0)	0.37(9.4)	0.87(22.2)
1/2	1/2	FT8-FA-FNPT8-	2.04(51.8)	0.78(19.8)	0.37(9.4)	1.06(27.0)
5/8	3/8	FT10-FA-FNPT6-	1.86(47.2)	0.59(15.0)	0.47(11.9)	0.87(22.2)
5/8	1/2	FT10-FA-FNPT8-	2.09(53.1)	0.78(19.8)	0.47(11.9)	1.06(27.0)
3/4	1/2	FT12-FA-FNPT8-	2.08(52.8)	0.78(19.8)	0.58(14.7)	1.06(27.0)
3/4	3/4	FT12-FA-FNPT12-	2.16(54.9)	0.81(20.6)	0.58(14.7)	1.31(33.3)
3/4	1	FT12-FA-FNPT16-	2.30(58.4)	1.00(25.4)	0.58(14.7)	1.63(41.3)
7/8	3/4	FT14-FA-FNPT12-	2.22(56.4)	0.81(20.6)	0.58(14.7)	1.31(33.3)
1	3/4	FT16-FA-FNPT12-	2.39(60.7)	0.81(20.6)	0.80(20.3)	1.31(33.3)
1	1	FT16-FA-FNPT16-	2.53(64.3)	1.00(25.4)	0.80(20.3)	1.63(41.3)
1 1/4	1 1/4	FT20-FA-FNPT20- [ⓐ]	3.06(77.7)	1.00(25.4)	1.02(25.9)	2.13(54.0)
1 1/2	1 1/2	FT24-FA-FNPT24- [ⓐ]	3.50(88.9)	1.09(27.7)	1.25(31.8)	2.37(60.3)

ⓐ Оснащен гайкой и предварительно обжатыми кольцами.

Дюймовая трубка

Коническая резьба ISO (RT)

Трубка, дюйм	P-RT Резьба	Артикул для заказа	Размеры, дюйм (мм)			
			L	B	E	F
1/4	1/8	FT4-FA-FBT2-	1.30(33.0)	0.41(10.4)	0.17(4.3)	0.56(14.3)
1/4	1/4	FT4-FA-FBT4-	1.45(36.8)	0.59(15.0)	0.17(4.3)	0.75(19.1)
3/8	1/4	FT6-FA-FBT4-	1.50(38.1)	0.59(15.0)	0.27(6.9)	0.75(19.1)
3/8	3/8	FT6-FA-FBT6-	1.59(40.4)	0.59(15.0)	0.27(6.9)	0.87(22.2)
1/2	1/4	FT8-FA-FBT4-	1.71(43.4)	0.59(15.0)	0.37(9.4)	0.75(19.1)
1/2	3/8	FT8-FA-FBT6-	1.80(45.7)	0.59(15.0)	0.37(9.4)	0.87(22.2)
1/2	1/2	FT8-FA-FBT8-	2.05(52.1)	0.78(19.8)	0.37(9.4)	1.06(27.0)

Трубный адаптер с внутренней резьбой

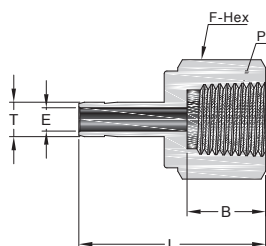

Метрическая трубка

Резьба NPT

Трубка, мм	P-NPT резьба	Артикул для заказа	Размеры, дюйм (мм)			
			L	B	E	F
3	1/8	MT3-FA-FNPT2-	28.8(1.13)	10.4(0.41)	1.3(0.05)	14.0(0.55)
4	1/8	MT4-FA-FNPT2-	33.3(1.31)	10.4(0.41)	2.0(0.08)	14.0(0.55)
6	1/8	MT6-FA-FNPT2-	32.5(1.28)	10.4(0.41)	4.1(0.16)	14.0(0.55)
6	1/4	MT6-FA-FNPT4-	37.1(1.46)	15.0(0.59)	4.1(0.16)	19.0(0.75)
8	1/8	MT8-FA-FNPT2-	35.1(1.38)	10.4(0.41)	6.4(0.25)	14.0(0.55)
8	1/4	MT8-FA-FNPT4-	37.6(1.48)	15.0(0.59)	5.6(0.22)	19.0(0.75)
8	3/8	MT8-FA-FNPT6-	36.5(1.44)	15.0(0.59)	6.4(0.25)	22.0(0.87)
10	1/4	MT10-FA-FNPT4-	38.1(1.50)	15.0(0.59)	7.1(0.28)	19.0(0.75)
10	3/8	MT10-FA-FNPT6-	40.1(1.58)	15.0(0.59)	7.1(0.28)	22.0(0.87)
10	1/2	MT10-FA-FNPT8-	46.5(1.83)	19.8(0.78)	7.1(0.28)	27.0(1.06)
12	1/4	MT12-FA-FNPT4-	43.7(1.72)	15.0(0.59)	8.8(0.35)	19.0(0.75)
12	3/8	MT12-FA-FNPT6-	42.9(1.69)	15.0(0.59)	9.1(0.36)	22.0(0.87)
12	1/2	MT12-FA-FNPT8-	52.3(2.06)	19.8(0.78)	8.8(0.35)	27.0(1.06)
16	1/2	MT16-FA-FNPT8-	49.2(1.94)	19.8(0.78)	12.7(0.50)	27.0(1.06)
18	3/4	MT18-FA-FNPT12-	52.4(2.06)	20.6(0.81)	14.0(0.55)	32.0(1.26)
20	1/2	MT20-FA-FNPT8-	50.0(1.97)	19.8(0.78)	15.0(0.59)	27.0(1.06)
20	3/4	MT20-FA-FNPT12-	53.2(2.09)	20.6(0.81)	15.1(0.59)	32.0(1.26)
25	1	MT25-FA-FNPT16-	66.7(2.63)	25.4(1.00)	19.8(0.78)	41.0(1.61)

Метрическая трубка

Коническая резьба ISO (BSPT)

Трубка, мм	P-BSPT Резьба	Артикул для заказа	Размеры, дюйм (мм)			
			L	B	E	F
3	1/8	MT3-FA-FBT2-	27.8(1.09)	10.4(0.41)	1.8(0.07)	14.0(0.55)
4	1/8	MT4-FA-FBT2-	28.6(1.13)	10.4(0.41)	2.0(0.08)	14.0(0.55)
6	1/8	MT6-FA-FBT2-	33.0(1.30)	10.4(0.41)	4.1(0.16)	14.0(0.55)
8	1/4	MT8-FA-FBT4-	37.6(1.48)	15.0(0.59)	5.6(0.22)	19.0(0.75)
10	1/4	MT10-FA-FBT4-	38.1(1.50)	15.0(0.59)	7.1(0.28)	19.0(0.75)
10	3/8	MT10-FA-FBT6-	36.5(1.44)	15.0(0.59)	7.5(0.30)	22.0(0.87)
10	1/2	MT10-FA-FBT8-	41.3(1.63)	19.8(0.78)	7.5(0.30)	27.0(1.06)
12	1/4	MT12-FA-FBT4-	40.5(1.59)	15.0(0.59)	9.1(0.36)	19.0(0.75)
12	3/8	MT12-FA-FBT6-	43.7(1.72)	15.0(0.59)	9.1(0.36)	22.0(0.87)
12	1/2	MT12-FA-FBT8-	46.8(1.84)	19.8(0.78)	9.1(0.36)	27.0(1.06)
16	1/2	MT16-FA-FBT8-	48.4(1.91)	19.8(0.78)	12.7(0.50)	27.0(1.06)
18	3/4	MT18-FA-FBT12-	52.4(2.06)	20.6(0.81)	14.0(0.55)	32.0(1.26)
20	3/4	MT20-FA-FBT12-	53.2(2.09)	20.6(0.81)	15.1(0.59)	32.0(1.26)
25	1	MT25-FA-FBT16-	66.7(2.63)	25.4(1.00)	19.8(0.78)	41.0(1.61)

Трубный адаптер с внутренней резьбой

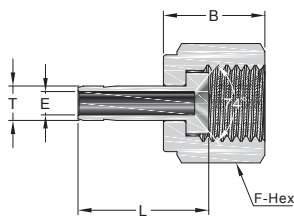
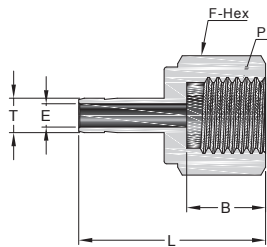

Трубный адаптер с внутренней резьбой

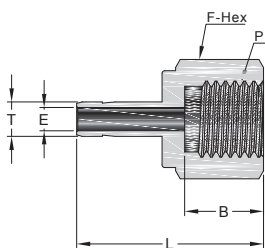
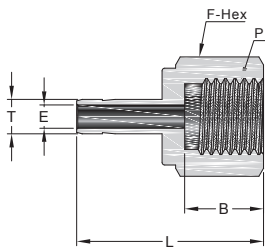

Дюймовая трубка

Цилиндрическая резьба ISO (BP)

Трубка, дюйм	P-BP Резьба	Артикул для заказа	Размеры, дюйм (мм)			
			L	B	E	F
1/8	1/8	FT2-FA-FBP2-	1.17(29.7)	0.40(10.2)	0.08(2.0)	0.56(14.3)
1/4	1/8	FT4-FA-FBP2-	1.25(31.8)	0.40(10.2)	0.17(4.3)	0.56(14.3)
1/4	1/4	FT4-FA-FBP4-	1.50(38.1)	0.60(15.2)	0.17(4.3)	0.75(19.1)
3/8	1/4	FT6-FA-FBP4-	1.55(39.4)	0.60(15.2)	0.27(6.9)	0.75(19.1)
3/8	3/8	FT6-FA-FBP6-	1.57(39.9)	0.60(15.2)	0.27(6.9)	0.94(23.8)
1/2	3/8	FT8-FA-FBP6-	1.78(45.2)	0.60(15.2)	0.38(9.7)	0.94(23.8)
1/2	1/2	FT8-FA-FBP8-	1.95(49.5)	0.72(18.2)	0.38(9.7)	1.06(27.0)

Дюймовая трубка

Резьба AN

Трубка, дюйм	Размер раструба трубки AN (дюймы)	Артикул для заказа	Размеры, дюйм (мм)			
			L	B	E	F
1/8	1/8	FT2-FA-SAN2-	0.88(22.4)	0.55(14.0)	0.09(2.4)	0.37(9.5)
1/8	1/4	FT2-FA-SAN4-	0.88(22.4)	0.62(15.8)	0.09(2.4)	0.56(14.3)
1/4	1/4	FT4-FA-SAN4-	0.96(24.4)	0.62(15.8)	0.18(4.6)	0.56(14.3)
3/8	3/8	FT6-FA-SAN6-	1.11(28.1)	0.73(18.5)	0.28(7.1)	0.69(17.5)
1/2	1/2	FT8-FA-SAN8-	1.42(36.1)	0.85(21.6)	0.39(9.9)	0.87(22.2)
3/4	3/4	FT12-FA-SAN12-	1.49(37.8)	1.03(26.2)	0.58(14.7)	1.25(31.8)

Метрическая трубка

Цилиндрическая резьба ISO (BG)

Трубка, мм	P-BG Резьба	Артикул для заказа	Размеры, дюйм (мм)			
			L	B	E	F
3	1/8	MT3-FA-FBP2-	28.6(1.13)	6.5(0.26)	1.6(0.06)	14.0(0.55)
3	1/4	MT3-FA-FBP4-	33.5(1.32)	10.2(0.40)	1.9(0.07)	19.0(0.75)
4	1/8	MT4-FA-FBP2-	29.4(1.16)	6.5(0.26)	2.0(0.08)	14.0(0.55)
6	1/8	MT6-FA-FBP2-	31.0(1.22)	6.5(0.26)	4.1(0.16)	14.0(0.55)
6	1/4	MT6-FA-FBP4-	35.3(1.39)	10.2(0.40)	4.1(0.16)	19.0(0.75)
6	3/8	MT6-FA-FBP6-	38.4(1.51)	14.2(0.56)	4.1(0.16)	24.0(0.94)
6	1/2	MT6-FA-FBP8-	42.9(1.69)	18.0(0.71)	4.1(0.16)	27.0(1.06)
8	1/4	MT8-FA-FBP4-	33.0(1.30)	10.2(0.40)	5.5(0.22)	19.0(0.75)
8	3/8	MT8-FA-FBP6-	38.9(1.53)	14.2(0.56)	5.6(0.22)	24.0(0.94)
8	1/2	MT8-FA-FBP8-	43.7(1.72)	18.0(0.71)	5.6(0.22)	27.0(1.06)
10	1/4	MT10-FA-FBP4-	34.5(1.36)	10.2(0.40)	5.5(0.22)	19.0(0.75)
10	3/8	MT10-FA-FBP6-	36.1(1.42)	14.2(0.56)	6.5(0.26)	24.0(0.94)
10	1/2	MT10-FA-FBP8-	41.1(1.62)	18.0(0.71)	7.1(0.28)	27.0(1.06)
12	1/4	MT12-FA-FBP4-	41.1(1.62)	10.2(0.40)	5.5(0.22)	19.0(0.75)
12	3/8	MT12-FA-FBP6-	44.7(1.76)	14.2(0.56)	6.5(0.26)	24.0(0.94)
12	1/2	MT12-FA-FBP8-	48.8(1.92)	18.0(0.71)	7.0(0.28)	27.0(1.06)
16	1/2	MT16-FA-FBP8-	49.0(1.93)	18.0(0.71)	7.0(0.28)	27.0(1.06)
18	1/2	MT18-FA-FBP8-	49.3(1.94)	18.0(0.71)	7.0(0.28)	27.0(1.06)

Метрическая трубка

Цилиндрическая резьба ISO (BG)

Трубка, мм	P-BG Резьба	Артикул для заказа	Размеры, дюйм (мм)			
			L	B	E	F
6	1/8	MT6-FA-FBP2-	32.0(1.26)	10.2(0.40)	4.1(0.16)	14.0(0.55)
6	1/4	MT6-FA-FBP4-	37.8(1.49)	15.2(0.60)	4.1(0.16)	19.0(0.75)
12	1/2	MT12-FA-FBP8-	49.8(1.96)	18.8(0.74)	8.8(0.35)	27.0(1.06)

Фланцевый переходник

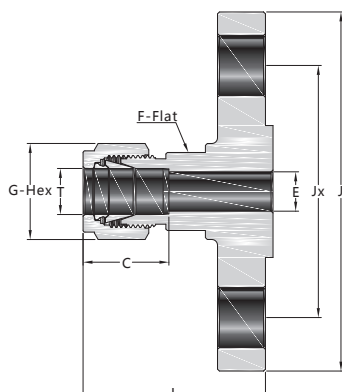

Фланцы по стандарту ASME

Трубка, мм	Размер фланца	Класс	Артикул для заказа	Размеры, дюйм (мм)						
				L	J	Jx	E	C	G	F
1/4	1/2	150	F4-FLA-RF8150-	40.9	88.9	60.5	4.8	15.2	14.3	20.6
3/8	1/2	300	F6-FLA-RF8150-	45.5	95.3	66.5	7.1	16.8	17.5	20.6
1/2	1/2	150	F8-FLA-RF8150-	45.2	88.9	60.5	10.4	22.9	22.2	20.6
1/2	1	150	F8-FLA-RF16150-	48.3	108.0	79.2	10.4	22.9	22.2	20.6
1/2	2	150	F8-FLA-RF32150-	53.1	152.4	121	10.4	22.9	22.2	20.6
3/4	1	150	F12-FLA-RF16150-	50.3	108.0	79.2	15.7	24.4	28.6	31.8
1	1	150	F16-FLA-RF16150-	60.5	108.0	79.2	22.4	31.2	38.1	34.9

Фланцы по стандарту DIN/GB, класс PN 40

Трубка, мм	Размер фланца	Артикул для заказа	Размеры, дюйм (мм)						
			L	J	Jx	E	C	G	F
6	25	M6-FLA-RF2540B1-	47.5(1.87)	115.0(4.53)	85.0(3.35)	4.8(0.19)	15.3(0.60)	14.0(0.55)	20.0(0.79)
12	15	M12-FLA-RF1540B1-	48.5(1.91)	95.0(3.74)	65.0(2.56)	9.5(0.37)	22.8(0.90)	22.0(0.87)	20.0(0.79)
12	25	M12-FLA-RF2540B1-	50.5(1.99)	115.0(4.53)	85.0(3.35)	9.5(0.37)	22.8(0.90)	22.0(0.87)	20.0(0.79)
12	50	M12-FLA-RF5040B1-	55.3(2.18)	165.0(6.50)	125.0(4.92)	9.5(0.37)	22.8(0.90)	22.0(0.87)	20.0(0.79)
18	15	M18-FLA-RF1540B1-	51.8(2.04)	95.0(3.74)	65.0(2.56)	15.1(0.59)	24.4(0.96)	30.0(1.18)	32.0(1.26)
18	25	M18-FLA-RF2540B1-	53.8(2.12)	115.0(4.53)	85.0(3.35)	15.1(0.59)	24.4(0.96)	30.0(1.18)	32.0(1.26)
25	25	M25-FLA-RF2540B1-	64.0(2.52)	115.0(4.53)	85.0(3.35)	21.8(0.86)	31.3(1.23)	38.0(1.50)	35.0(1.38)

Фланцы по стандарту EN, класс PN 40

Трубка, мм	Размер фланца	Артикул для заказа	Размеры, дюйм (мм)						
			L	J	Jx	E	C	G	F
6	25	M6-FLA-RF25E40B1-	47.5(1.87)	115.0(4.53)	85.0(3.35)	4.8(0.19)	15.3(0.60)	14.0(0.55)	20.0(0.79)
12	15	M12-FLA-RF15E40B1-	48.5(1.91)	95.0(3.74)	65.0(2.56)	9.5(0.37)	22.8(0.90)	22.0(0.87)	20.0(0.79)
12	25	M12-FLA-RF25E40B1-	50.5(1.99)	115.0(4.53)	85.0(3.35)	9.5(0.37)	22.8(0.90)	22.0(0.87)	20.0(0.79)
12	50	M12-FLA-RF50E40B1-	55.3(2.18)	165.0(6.50)	125.0(4.92)	9.5(0.37)	22.8(0.90)	22.0(0.87)	20.0(0.79)
18	15	M18-FLA-RF15E40B1-	51.8(2.04)	95.0(3.74)	65.0(2.56)	15.1(0.59)	24.4(0.96)	30.0(1.18)	32.0(1.26)
18	25	M18-FLA-RF25E40B1-	53.8(2.12)	115.0(4.53)	85.0(3.35)	15.1(0.59)	24.4(0.96)	30.0(1.18)	32.0(1.26)
25	25	M25-FLA-RF25E40B1-	64.0(2.52)	115.0(4.53)	85.0(3.35)	21.8(0.86)	31.3(1.23)	38.0(1.50)	35.0(1.38)

Фланцы по стандарту JIS, класс 10K

Трубка, мм	Размер фланца	Артикул для заказа	Размеры, дюйм (мм)						
			L	J	Jx	E	C	G	F
1/4	15	F4-FLA-RF1510K-	1.66(42.2)	3.74(95.0)	2.76(70.1)	0.19(4.8)	0.60(15.2)	0.56(14.3)	0.81(20.6)
3/8	15	F6-FLA-RF1510K-	1.72(43.7)	3.74(95.0)	2.76(70.1)	0.28(7.1)	0.66(16.8)	0.69(17.5)	0.81(20.6)
1/2	15	F8-FLA-RF1510K-	1.83(46.5)	3.74(95.0)	2.76(70.1)	0.41(10.4)	0.90(22.9)	0.87(22.2)	0.81(20.6)
3/4	15	F12-FLA-RF1510K-	1.91(48.5)	3.74(95.0)	2.76(70.1)	0.62(15.7)	0.96(24.4)	1.13(28.6)	1.25(31.8)
1	25	F16-FLA-RF2510K-	2.40(61.0)	4.92(125.0)	3.54(89.9)	0.88(22.4)	1.23(31.2)	1.50(38.1)	1.37(34.9)
12mm	15	M12-FLA-RF1510K-	1.83(46.5)	3.74(95.0)	2.76(70.0)	0.37(9.5)	0.90(22.8)	0.87(22.0)	0.79(20.0)
18mm	15	M18-FLA-RF1510K-	1.91(48.5)	3.74(95.0)	2.76(70.0)	0.59(15.1)	0.96(24.4)	1.18(30.0)	1.26(32.0)
25mm	25	M25-FLA-RF2510K-	2.40(61.0)	4.92(125.0)	3.54(90.0)	0.86(21.8)	1.23(31.3)	1.50(38.0)	1.38(35.0)

Переходник с санитарного фланца

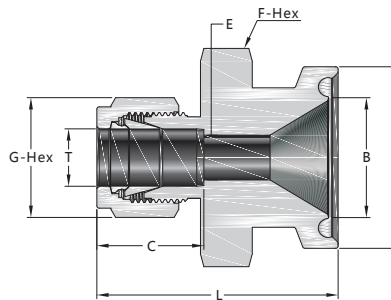

Дюймовая трубка

Трубка, дюйм	Размер фланца	Артикул для заказа	Размеры, дюйм (мм)						
			L	B	C	E	F	J	G
1/4	1/2	F4-SFF-SF8-	1.57(39.9)	0.37(9.4)	0.60(15.2)	0.19(4.8)	1.00(25.4)	0.98(24.9)	0.98(24.9)
1/4	3/4	F4-SFF-SF12-	1.57(39.9)	0.62(15.7)	0.60(15.2)	0.19(4.8)	1.00(25.4)	0.98(24.9)	0.98(24.9)
1/4	1	F4-SFF-SF16-	1.57(39.9)	0.87(22.1)	0.60(15.2)	0.19(4.8)	1.37(34.9)	1.98(50.3)	1.98(50.3)
1/4	1 1/2	F4-SFF-SF24-	1.57(39.9)	1.37(34.8)	0.60(15.2)	0.19(4.8)	1.37(34.9)	1.98(50.3)	1.98(50.3)
3/8	1/2	F6-SFF-SF8-	1.63(41.4)	0.30(7.6)	0.66(16.8)	0.28(7.1)	1.00(25.4)	0.98(24.9)	0.98(24.9)
3/8	3/4	F6-SFF-SF12-	1.63(41.4)	0.62(15.7)	0.66(16.8)	0.28(7.1)	1.00(25.4)	0.98(24.9)	0.98(24.9)
3/8	1	F6-SFF-SF16-	1.63(41.4)	0.87(22.1)	0.66(16.8)	0.28(7.1)	1.37(34.9)	1.98(50.3)	1.98(50.3)
3/8	1 1/2	F6-SFF-SF24-	1.63(41.4)	1.37(34.8)	0.66(16.8)	0.28(7.1)	1.37(34.9)	1.98(50.3)	1.98(50.3)
1/2	1/2	F8-SFF-SF8-	1.74(44.2)	0.30(7.6)	0.90(22.9)	0.37(9.4)	1.00(25.4)	0.98(24.9)	0.98(24.9)
1/2	3/4	F8-SFF-SF12-	1.74(44.2)	0.62(15.7)	0.90(22.9)	0.41(10.4)	1.00(25.4)	0.98(24.9)	0.98(24.9)
1/2	1	F8-SFF-SF16-	1.74(44.2)	0.87(22.1)	0.90(22.9)	0.41(10.4)	1.37(34.9)	1.98(50.3)	1.98(50.3)
1/2	1 1/2	F8-SFF-SF24-	1.74(44.2)	1.37(34.8)	0.90(22.9)	0.41(10.4)	1.37(34.9)	1.98(50.3)	1.98(50.3)
1	1	F16-SFF-SF16-	1.91(48.5)	0.87(22.1)	1.23(31.2)	0.87(22.1)	1.37(34.9)	1.98(50.3)	1.98(50.3)
1	2	F16-SFF-SF32-	2.49(63.2)	1.37(34.8)	1.23(31.2)	0.88(22.4)	2.75(69.9)	2.52(64.0)	2.52(64.0)

Штуцер под приварку

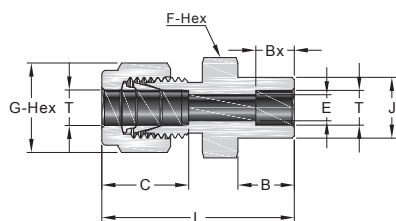

Дюймовая трубка

Под приварку внахлест

Трубка, дюйм	Артикул для заказа	Размеры, мм							
		L	C	G	F	B	E	Bx	J
1/8	F2-WC-FSW2-	29.0	12.7	11.1	11.1	8.6	2.3	2.5	7.9
3/16	F3-WC-FSW3-	29.7	13.7	12.7	11.1	9.5	3.3	4.8	10.7
1/4	F4-WC-FSW4-	33.5	15.2	14.3	12.7	10.4	4.8	7.1	11.2
3/8	F6-WC-FSW6-	37.6	16.8	17.5	15.9	11.9	7.1	7.9	15.7
1/2	F8-WC-FSW8-	41.1	22.9	22.2	20.6	11.9	10.4	9.7	19.1
5/8	F10-WC-FSW10-	41.9	24.4	25.4	23.8	11.9	12.7	10.4	23.4
3/4	F12-WC-FSW12-	43.4	24.4	28.6	27.0	11.9	15.7	11.1	26.7
1	F16-WC-FSW16-	52.6	31.2	38.1	34.9	14.2	22.4	15.7	33.3

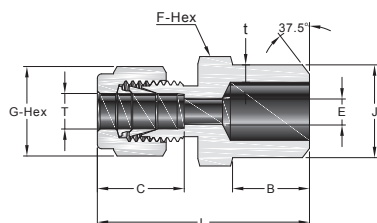

Дюймовая трубка

Под приварку встык

Трубка, дюйм	Трубка под приварку	Артикул для заказа	Размеры, мм							
			L	C	G	F	E	B	J	t
1/8	1/8	F2-WC-PBW2-	30.5	12.7	11.1	11.1	2.3	9.7	10.3	2.4
3/16	1/8	F3-WC-PBW2-	31.2	13.7	12.7	11.1	3.0	9.7	10.3	2.4
1/4	1/8	F4-WC-PBW2-	32.8	15.2	14.3	12.7	4.8	9.7	10.3	2.4
1/4	1/4	F4-WC-PBW4-	37.8	15.2	14.3	14.3	4.8	14.2	13.7	3.0
5/16	1/8	F5-WC-PBW2-	34.0	16.3	15.9	14.3	5.3	9.7	10.3	2.4
5/16	1/4	F5-WC-PBW4-	38.6	16.3	15.9	14.3	6.4	14.2	13.7	3.0
3/8	1/4	F6-WC-PBW4-	39.9	16.8	17.5	15.9	7.1	14.2	13.7	3.0
3/8	3/8	F6-WC-PBW6-	39.9	16.8	17.5	17.5	7.1	14.2	17.1	3.2
3/8	1/2	F6-WC-PBW8-	46.2	16.8	17.5	22.2	7.1	19.1	21.3	3.7
3/8	3/4	F6-WC-PBW12-	47.8	16.8	17.5	27.0	7.1	19.1	26.7	3.9
1/2	3/8	F8-WC-PBW6-	43.4	22.9	22.2	20.6	10.4	14.2	17.1	3.2
1/2	1/2	F8-WC-PBW8-	49.0	22.9	22.2	22.2	10.4	19.1	21.3	3.7
1/2	3/4	F8-WC-PBW12-	50.5	22.9	22.2	27.0	10.4	19.1	26.7	3.9
5/8	1/2	F10-WC-PBW8-	49.0	24.4	25.4	23.8	12.7	19.1	21.3	3.7
3/4	1/2	F12-WC-PBW8-	50.5	24.4	28.6	27.0	14.0	19.1	21.3	3.7
3/4	3/4	F12-WC-PBW12-	50.5	24.4	28.6	27.0	15.7	19.1	26.7	3.9
1	1	F16-WC-PBW16-	62.2	31.2	38.1	34.9	22.4	23.9	33.4	4.5
1 1/4	1 1/4	F20-WC-PBW20-	77.2	41.1	47.6	44.5	27.7	23.9	42.2	4.9
1 1/2	1 1/2	F24-WC-PBW24-	88.9	50.0	57.2	54.0	34.0	26.2	48.3	5.1

Штуцер под приварку

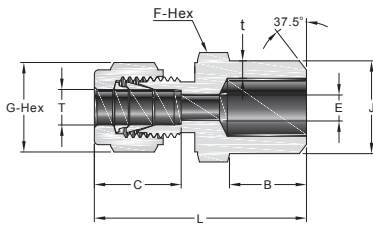

Метрическая трубка

Под приварку встык

Трубка, мм	Трубка под приварку	Артикул для заказа	Размеры, мм						
			L	C	G	F	E	B	t
3	1/8	M3-WC-PBW2-	30.5	12.9	12	12	2.4	9.7	2.4
4	1/8	M4-WC-PBW2-	31.5	13.7	12	12	2.4	9.7	2.4
6	1/8	M6-WC-PBW2-	32.8	15.3	14	14	4.8	9.7	2.4
6	1/4	M6-WC-PBW4-	37.9	15.3	14	14	4.8	14.2	3.0
8	1/8	M8-WC-PBW2-	34.2	16.2	16	15	5.4	9.7	2.4
8	1/4	M8-WC-PBW4-	38.7	16.2	16	15	6.4	14.2	3.0
8	1/2	M8-WC-PBW8-	45.6	16.2	16	22	6.4	19.1	3.7
10	1/4	M10-WC-PBW4-	40.9	17.2	19	18	7.5	14.2	3.0
10	3/8	M10-WC-PBW6-	40.9	17.2	19	18	7.9	14.2	3.2
10	1/2	M10-WC-PBW8-	46.5	17.2	19	22	7.9	19.1	3.7
12	1/4	M12-WC-PBW4-	43.4	22.8	22	22	7.5	14.2	3.0
12	3/8	M12-WC-PBW6-	43.4	22.8	22	22	9.5	14.2	3.2
12	1/2	M12-WC-PBW8-	49.0	22.8	22	22	9.5	19.1	3.7
14	3/8	M14-WC-PBW6-	44.1	24.4	25	24	10.7	14.2	3.2
15	1/2	M15-WC-PBW8-	49.0	24.4	25	24	11.9	19.1	3.7
16	1/2	M16-WC-PBW8-	49.0	24.4	25	24	12.7	19.1	3.7
18	1/2	M18-WC-PBW8-	50.5	24.4	30	27	13.9	19.1	3.7
30	1 1/4	M30-WC-PBW20-	77.2	39.6	50	46	26.2	23.9	4.9
32	1 1/4	M32-WC-PBW20-	79.6	42.0	50	46	28.6	23.9	4.9
38	1 1/2	M38-WC-PBW24-	91.6	49.4	60	55	33.7	26.2	5.1

Соединительный угольник под приварку

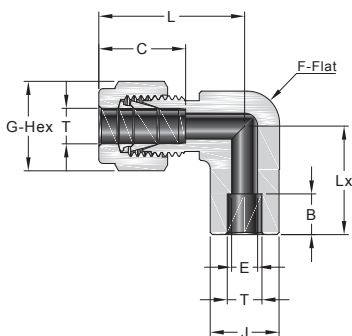

Дюймовая трубка

Под приварку в раструб

Трубка, дюйм	Артикул для заказа	Размеры, мм							
		L	C	G	F	B	E	Lx	J
1/8	F2-WE-FSW2-	16.8	12.7	11.1	9.5	2.5	2.3	16.0	9.7
3/16	F3-WE-FSW3-	18.3	13.7	12.7	11.1	4.8	3.3	17.5	11.2
1/4	F4-WE-FSW4-	26.9	15.2	14.3	12.7	7.1	4.8	19.6	12.7
3/8	F6-WE-FSW6-	30.5	16.8	17.5	15.9	7.9	7.1	23.1	15.7
1/2	F8-WE-FSW8-	36.1	22.9	22.2	20.6	9.7	10.4	25.9	20.6
5/8	F10-WE-FSW10-	29.5	24.4	25.4	27.0	10.4	12.7	29.5	23.9
3/4	F12-WE-FSW12-	39.9	24.4	28.6	27.0	11.2	15.7	29.7	26.9
1	F16-WE-FSW16-	49.0	31.2	38.1	34.9	15.7	22.4	36.8	35.1

Соединительный угольник под приварку

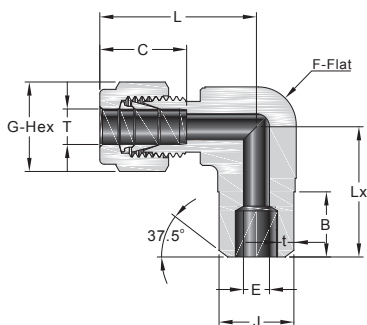

Дюймовая трубка

Под приварку встык

Трубка, дюйм	Трубка под приварку	Артикул для заказа	Размеры, мм							
			L	C	G	F	B	E	Lx	J
1/8	1/8	F2-WE-PBW2-	23.4	12.7	11.1	11.1	9.7	2.3	18.3	10.3
3/16	1/8	F3-WE-PBW2-	25.7	13.7	12.7	12.7	9.7	3.3	18.8	10.3
1/4	1/8	F4-WE-PBW2-	26.9	15.2	14.3	12.7	9.7	4.8	18.8	10.3
1/4	1/4	F4-WE-PBW4-	26.9	15.2	14.3	12.7	14.2	4.8	23.4	13.7
3/8	1/4	F6-WE-PBW4-	30.5	16.8	17.5	15.9	14.2	7.1	25.4	13.7
1/2	3/8	F8-WE-PBW6-	34.8	22.9	22.2	19.1	14.2	10.4	28.8	17.2
1/2	1/2	F8-WE-PBW8-	36.1	22.9	22.2	20.6	19.1	10.4	33.0	21.3
5/8	1/2	F10-WE-PBW8-	36.3	24.4	25.4	23.8	19.1	12.7	35.1	21.3
3/4	3/4	F12-WE-PBW12-	39.9	24.4	28.6	27.0	19.1	15.7	36.8	26.7
1	3/4	F16-WE-PBW12-	49.3	31.2	38.1	34.9	19.1	22.4	41.9	26.7
1	1	F16-WE-PBW16-	49.3	31.2	38.1	34.9	20.6	22.4	46.7	33.4

Гайка

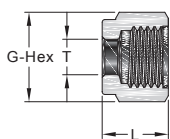

Дюймовая трубка

Трубка, дюйм	Артикул для заказа	Размеры, дюйм (мм)	
		L	G
1/16	N-F1-	0.31(7.9)	0.31(7.9)
1/8	N-F2-	0.47(11.9)	0.44(11.1)
3/16	N-F3-	0.47(11.9)	0.50(12.7)
1/4	N-F4-	0.50(12.7)	0.56(14.3)
5/16	N-F5-	0.53(13.5)	0.63(15.9)
3/8	N-F6-	0.56(14.2)	0.69(17.5)
1/2	N-F8-	0.69(17.5)	0.87(22.2)
5/8	N-F10-	0.69(17.5)	1.00(25.4)
3/4	N-F12-	0.69(17.5)	1.13(28.6)
7/8	N-F14-	0.69(17.5)	1.25(31.8)
1	N-F16-	0.81(20.6)	1.50(38.1)
1 1/8	N-F18-	1.21(30.8)	1.81(46.0)
1 1/4	N-F20-	1.25(31.8)	1.87(47.6)
1 1/2	N-F24-	1.50(38.1)	2.25(57.2)

Метрическая трубка

Трубка, мм	Артикул для заказа	Размеры, дюйм (мм)	
		L	G
2	N-M2-	11.9(0.47)	12.0(0.47)
3	N-M3-	11.9(0.47)	12.0(0.47)
4	N-M4-	11.9(0.47)	12.0(0.47)
6	N-M6-	12.7(0.50)	14.0(0.55)
8	N-M8-	13.5(0.53)	16.0(0.63)
10	N-M10-	15.1(0.59)	19.0(0.75)
12	N-M12-	17.4(0.69)	22.0(0.87)
14	N-M14-	17.4(0.69)	25.0(0.98)
15	N-M15-	17.4(0.69)	25.0(0.98)
16	N-M16-	17.4(0.69)	25.0(0.98)
18	N-M18-	17.4(0.69)	30.0(1.18)
20	N-M20-	17.4(0.69)	32.0(1.26)
22	N-M22-	17.4(0.69)	32.0(1.26)
25	N-M25-	20.6(0.81)	38.0(1.50)
28	N-M28-	30.6(1.20)	46.0(1.81)
30	N-M30-	32.7(1.29)	50.0(1.97)
32	N-M32-	34.4(1.35)	50.0(1.97)
38	N-M38-	40.6(1.60)	60.0(2.36)

Гайки

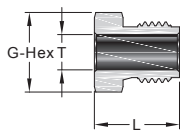

Дюймовая трубка

Трубка, дюйм	Артикул для заказа	Размеры, дюйм (мм)	
		L	G
1/16	MN-F1-	0.38(9.7)	0.25(6.4)
1/8	MN-F2-	0.53(13.5)	0.37(9.5)
1/4	MN-F4-	0.62(15.7)	0.50(12.7)
1/2	MN-F8-	0.87(22.1)	0.94(23.8)

Метрическая трубка

Трубка, мм	Артикул для заказа	Размеры, дюйм (мм)	
		L	G
3	MN-M3-	13.5(0.53)	10.0(0.39)
6	MN-M6-	15.7(0.62)	14.0(0.55)
10	MN-M10-	22.1(0.87)	22.0(0.87)
12	MN-M12-	22.1(0.87)	24.0(0.94)

Передние обжимные кольца



Дюймовая трубка

Трубка, дюйм	Артикул для заказа
1/16	FF-F1
1/8	FF-F2
3/16	FF-F3
1/4	FF-F4
5/16	FF-F5
3/8	FF-F6
1/2	FF-F8
5/8	FF-F10
3/4	FF-F12
7/8	FF-F14
1	FF-F16
1 1/8	FF-F18
1 1/4	FF-F20
1 1/2	FF-F24

Метрическая трубка

Трубка, мм	Артикул для заказа
2	FF-M2
3	FF-M3
4	FF-M4
6	FF-M6
8	FF-M8
10	FF-M10
12	FF-M12
14	FF-M14
15	FF-M15
16	FF-M16
18	FF-M18
20	FF-M20
22	FF-M22
25	FF-M25
28	FF-M28
30	FF-M30
32	FF-M32
38	FF-M38

Задние обжимные кольца



Дюймовая трубка

Трубка, дюйм	Артикул для заказа
1/16	RF-F1
1/8	RF-F2
3/16	RF-F3
1/4	RF-L4
5/16	RF-F5
3/8	RF-L6
1/2	RF-F8
5/8	RF-F10
3/4	RF-F12
7/8	RF-F14
1	RF-F16
1 1/8	RF-F18
1 1/4	RF-F20
1 1/2	RF-F24

Метрическая трубка

Трубка, мм	Артикул для заказа
2	RF-M2
3	RF-M3
4	RF-M4
6	RF-M6
8	RF-M8
10	RF-M10
12	RF-M12
14	RF-M14
15	RF-M15
16	RF-M16
18	RF-M18
20	RF-M20
22	RF-M22
25	RF-M25
28	RF-M28
30	RF-M30
32	RF-M32
38	RF-M38

Комплект обжимных колец и гайки

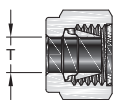

Дюймовая трубка

Трубка, дюйм для заказа	Артикул
1/16	NFR-F1
1/8	NFR-F2
3/16	NFR-F3
1/4	NFR-F4
5/16	NFR-F5
3/8	NFR-F6
1/2	NFR-F8
5/8	NFR-F10
3/4	NFR-F12
7/8	NFR-F14
1	NFR-F16
1 1/8	NFR-F18
1 1/4	NFR-F20
1 1/2	NFR-F24

Метрическая трубка

Трубка, мм для заказа	Артикул
2	NFR-M2
3	NFR-M3
4	NFR-M4
6	NFR-M6
8	NFR-M8
10	NFR-M10
12	NFR-M12
14	NFR-M14
15	NFR-M15
16	NFR-M16
18	NFR-M18
20	NFR-M20
22	NFR-M22
25	NFR-M25
28	NFR-M28
30	NFR-M30
32	NFR-M32
38	NFR-M38

Комплект обжимных колец и гайки



Каждый комплект состоит из 5 гаек, 5 передних колец и 5 задних.

Дюймовая трубка

Трубка, дюйм для заказа	Артикул
1/16	NFS-F1-
1/8	NFS-F2-
3/16	NFS-F3-
1/4	NFS-F4-
5/16	NFS-F5-
3/8	NFS-F6-
1/2	NFS-F8-
5/8	NFS-F10-
3/4	NFS-F12-

Метрическая трубка

Трубка, мм для заказа	Артикул
2	NFS-M2-
3	NFS-M3-
4	NFS-M4-
6	NFS-M6-
8	NFS-M8-
10	NFS-M10-
12	NFS-M12-
14	NFS-M14-
15	NFS-M15-
16	NFS-M16-
18	NFS-M18-

Набор обжимных колец



Каждый набор обжимных колец состоит из 10 передних и 10 задних колец.

Дюймовая трубка

Трубка, дюйм	Артикул для заказа
1/16	FRS-F1-
1/8	FRS-F2-
3/16	FRS-F3-
1/4	FRS-F4-
5/16	FRS-F5-
3/8	FRS-F6-
1/2	FRS-F8-
5/8	FRS-F10-
3/4	FRS-F12-

Метрическая трубка

Трубка, мм	Артикул для заказа
2	FRS-M2-
3	FRS-M3-
4	FRS-M4-
6	FRS-M6-
8	FRS-M8-
10	FRS-M10-
12	FRS-M12-
14	FRS-M14-
15	FRS-M15-
16	FRS-M16-
18	FRS-M18-

Вставки для мягких трубок

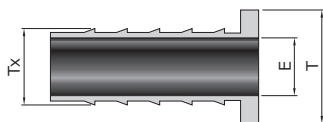

Дюймовая трубка

Т- Трубка, дюйм	Тх- Трубка, дюйм	Артикул для заказа	Е дюйм (мм)
3/16	1/8	ISPF-3-2-	0.09(2.3)
1/4	1/8	ISPF-4-2-	0.09(2.3)
1/4	0.17	ISPF-4-017-	0.11(2.8)
1/4	3/16	ISPF-4-3-	0.14(3.5)
5/16	1/8	ISPF-5-2-	0.09(2.3)
5/16	3/16	ISPF-5-3-	0.12(3.0)
5/16	1/4	ISPF-5-4-	0.19(4.8)
3/8	3/16	ISPF-6-3-	0.12(3.0)
3/8	1/4	ISPF-6-4-	0.19(4.8)
1/2	1/4	ISPF-8-4-	0.19(4.8)
1/2	3/8	ISPF-8-6-	0.31(7.9)
5/8	3/8	ISPF-10-6-	0.31(7.9)
5/8	1/2	ISPF-10-8-	0.44(11.1)
3/4	1/2	ISPF-12-8-	0.44(11.1)
3/4	5/8	ISPF-12-10-	0.56(14.2)
1	3/4	ISPF-16-12-	0.69(17.5)

Метрическая трубка

Т- Трубка, мм	Тх- Трубка, мм	Артикул для заказа	Е дюйм (мм)
6	4	ISPM-6-4-	2.8(0.11)
8	6	ISPM-8-6-	4.4(0.17)
10	8	ISPM-10-8-	6.4(0.25)
12	8	ISPM-12-8-	6.4(0.25)
12	10	ISPM-12-10-	8.3(0.33)

Комбинированные уплотнительные кольца BS

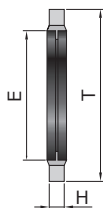

Размер цилиндрической резьбы ISO	Артикул для заказа	Размеры, дюйм (мм)		
		T	E	H
1/8	BS-2-	0.63(16.0)	0.41(10.4)	0.08(2.0)
1/4	BS-4-	0.81(20.6)	0.54(13.7)	
3/8	BS-6-	0.94(23.9)	0.68(17.3)	
1/2	BS-8-	1.13(28.7)	0.85(21.6)	0.10(2.5)
3/4	BS-12-	1.38(35.1)	1.06(26.9)	
1	BS-16-	1.69(42.9)	1.33(33.8)	

Размер метрической резьбы	Артикул для заказа	Размеры, дюйм (мм)		
		T	E	H
M8 x 1	BS-MS8-	13.0(0.51)	8.7(0.34)	1.0(0.04)
M10 x 1	BS-MS10-	16.0(0.63)	10.7(0.42)	
M12 x 1.5	BS-MS12-	18.0(0.71)	12.7(0.50)	
M14 x 1.5	BS-MS14-	22.0(0.87)	14.7(0.58)	
M16 x 1.5	BS-MS16-	24.0(0.94)	16.7(0.66)	
M18 x 1.5	BS-MS18-	26.0(1.02)	18.7(0.74)	
M20 x 1.5	BS-MS20-	28.0(1.10)	20.7(0.81)	1.5(0.06)
M22 x 1.5	BS-MS22-	30.0(1.18)	22.7(0.89)	
M24 x 1.5	BS-MS24-	32.0(1.26)	24.7(0.97)	
M27 x 2	BS-MS27-	36.0(1.42)	27.2(1.07)	
M30 x 2	BS-MS30-	39.0(1.54)	30.7(1.21)	2.0(0.08)
M33 x 2	BS-MS33-	42.0(1.65)	33.7(1.33)	
M36 x 2	BS-MS36-	48.0(1.89)	37.0(1.46)	
M39 x 2	BS-MS39-	51.0(2.01)	40.0(1.57)	2.5(0.10)
M42 x 2	BS-MS42-	53.0(2.09)	42.7(1.68)	
M45 x 2	BS-MS45-	57.0(2.24)	46.0(1.81)	3.0(0.12)
M48 x 2	BS-MS48-	59.0(2.32)	48.7(1.92)	

❖ Уплотнительные кольца BS служат для уплотнения цилиндрических ISO и метрических резьб

Информация для заказа

❖ Добавьте обозначение материала в конце артикула.

Кольцо		Обозначение
Внешнее	Внутреннее	
Нержавеющая сталь 316	FKM	316
Углеродистая сталь	Vuna-N	CS

Пример:

- ❖ Для заказа уплотнительного кольца под резьбу 1/8" из углеродистой стали со вставкой из Vuna, номер для заказа BS-2-CS
- ❖ Кольца BS используется с фитингами BS.

Уплотнительные медные кольца для внешней резьбы ВР

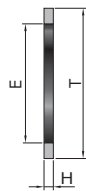

Размер цилиндрической резьбы ISO	Артикул для заказа	Размеры, дюйм (мм)		
		T	E	H
1/8	BP-2-	0.59(15.0)	0.39(9.9)	0.06(1.5)
1/4	BP-4-	0.75(19.1)	0.52(13.2)	
3/8	BP-6-	0.91(23.1)	0.66(16.8)	
1/2	BP-8-	1.06(26.9)	0.83(21.1)	0.08(2.0)
3/4	BP-12-	1.30(33.0)	1.05(26.7)	
1	BP-16-	1.69(40.1)	1.31(33.2)	

Размер метрической резьбы	Артикул для заказа	Размеры, дюйм (мм)		
		T	E	H
M8 x 1	BP-MS8-	13.2(0.52)	8.2(0.32)	1.5(0.06)
M10 x 1	BP-MS10-	15.2(0.60)	10.2(0.40)	
M12 x 1.5	BP-MS12-	18.2(0.72)	12.2(0.48)	
M14 x 1.5	BP-MS14-	20.2(0.80)	14.2(0.56)	2.0(0.08)
M16 x 1.5	BP-MS16-	22.2(0.87)	16.2(0.64)	
M18 x 1.5	BP-MS18-	24.2(0.95)	18.2(0.72)	
M20 x 1.5	BP-MS20-	26.2(1.03)	20.2(0.80)	
M22 x 1.5	BP-MS22-	28.2(1.11)	22.2(0.87)	
M24 x 1.5	BP-MS24-	30.2(1.19)	24.2(0.95)	
M27 x 2	BP-MS27-	33.3(1.31)	27.2(1.07)	2.5(0.10)
M30 x 2	BP-MS30-	37.3(1.47)	30.2(1.19)	
M33 x 2	BP-MS33-	40.3(1.59)	33.2(1.37)	
M36 x 2	BP-MS36-	43.3(1.70)	36.2(1.43)	
M39 x 2	BP-MS39-	47.3(1.86)	39.2(1.54)	
M42 x 2	BP-MS42-	50.3(1.98)	42.2(1.66)	
M45 x 2	BP-MS45-	53.3(2.10)	45.2(1.78)	
M48 x 2	BP-MS48-	56.3(2.22)	48.2(1.90)	

❖ Уплотнительные кольца BS служат для уплотнения цилиндрических ISO и метрических резьб

❖ Кольца BP используется с фитингами ВР.

Комбинированные уплотнительные кольца ВГ

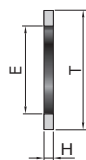

Размер цилиндрической резьбы ISO	Артикул для заказа	Размеры, дюйм (мм)		
		T	E	H
1/4	BG-4-	0.42(10.7)	0.30(7.6)	0.08(2.0)
3/8	BG-6-	0.56(14.2)	0.34(8.6)	0.08(2.0)
1/2	BG-8-	0.70(17.8)	0.36(9.1)	0.10(2.5)

Размер метрической резьбы	Артикул для заказа	Размеры, дюйм (мм)		
		T	E	H
M10 x 1	BG-MS10-	8.3(0.33)	3.3(0.13)	1.5(0.06)
M12 x 1.5	BG-MS12-	9.7(0.38)	5.4(0.21)	
M14 x 1.5	BG-MS14-	11.7(0.46)	6.4(0.25)	
M16 x 1.5	BG-MS16-	13.7(0.54)	8.4(0.33)	2.0(0.08)
M18 x 1.5	BG-MS18-	15.7(0.62)	10.0(0.39)	
M20 x 1.5	BG-MS20-	18.0(0.71)	8.0(0.31)	
M22 x 1.5	BG-MS22-	19.6(0.77)	13.4(0.53)	
M24 x 1.5	BG-MS24-	21.6(0.85)	14.8(0.58)	
M27 x 2	BG-MS27-	24.0(0.94)	13.9(0.55)	
M30 x 2	BG-MS30-	27.0(1.06)	19.5(0.77)	2.5(0.10)
M33 x 2	BG-MS33-	30.0(1.18)	21.5(1.85)	
M36 x 2	BG-MS36-	33.0(1.30)	23.5(0.93)	
M39 x 2	BG-MS39-	36.0(1.42)	24.5(1.00)	
M42 x 2	BG-MS42-	38.9(1.53)	29.5(1.16)	
M45 x 2	BG-MS45-	41.9(1.65)	30.0(1.18)	
M48 x 2	BG-MS48-	44.9(1.77)	32.5(1.28)	

Информация для заказа

❖ Добавьте обозначение материала в конце артикула.

Материал	Обозначение
Медь	CU
Нержавеющая сталь 316	316
PTFE	PTFE

❖ Пример: BP-8-CU, BG-4-316, BG-MS14-CU.

Уплотнительные кольца из эластомеров



Кольца для фитингов с прямой резьбой SAE/MS

SAE/MS Размер резьбы	Артикул для заказа	Материал
5/16-24	FKM9-902	90 Durometer Fluorocarbon FKM
3/8-24	FKM9-903	
7/16-20	FKM9-904	
1/2-20	FKM9-905	
9/16-18	FKM9-906	
3/4-16	FKM9-908	
7/8-14	FKM9-910	
1 1/16-12	FKM9-912	
1 3/16-12	FKM9-914	
1 5/16-12	FKM9-916	
1 5/8-12	FKM9-920	
1 7/8-12	FKM9-924	

Кольца для фитингов с трубными резьбами

NPT/ISO Размер резьбы	Артикул для заказа	Материал
1/8	NBR7-013	70 Durometer NBR
1/4	NBR7-113	
3/8	NBR7-116	
1/2	NBR7-118	

Кольца для фитингов с цилиндрической резьбой ISO

Размер резьбы ISO	Артикул для заказа	Материал
1/8	FKM9-502	90 Durometer Fluorocarbon FKM
1/4	FKM9-111	
3/8	FKM9-113	
1/2	FKM9-508	
3/4	FKM9-119	
1	FKM9-217	

Кольца для фитингов с цилиндрической резьбой под уплотнение

SAE/MS Размер резьбы	Артикул для заказа	Материал
5/16-24	NBR7-011	70 Durometer NBR
3/8-24	NBR7-012	
7/16-20	NBR7-013	
1/2-20	NBR7-112	
9/16-18	NBR7-113	
3/4-16	NBR7-116	
1 1/16-12	NBR7-121	
1 5/16-12	NBR7-125	

Фиксатор для монтажа на панель

- ❖ Используя фиксатор переборки, один человек может затянуть стопорную гайку на стороне А для первоначальной установки фитинга переборки. Теперь трубы могут быть подсоединены к сторонам А и В одним человеком одним гаечным ключом, поскольку фиксатор переборки действует как запасной ключ.

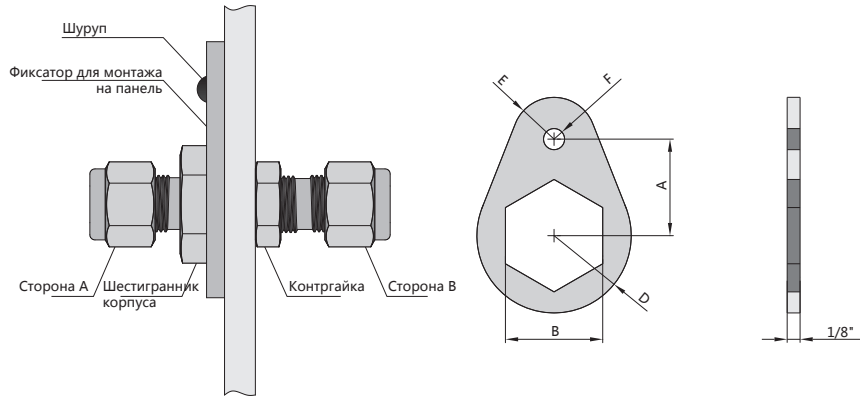

Размер фитинга		Артикул для заказа	Размеры, дюйм				
дюйм	мм		A	B	D	E	F
1/16	—	BR-01-316	3/8	5/16	5/16	5/32	5/32
1/8	—	BR-02-316	1/2	1/2	13/32	7/32	
3/16	3,4	BR-03-316	9/16	9/16	15/32	1/4	
1/4	6	BR-04-316	5/8	5/8	1/2	9/32	
5/16	—	BR-05-316	11/16	11/16	9/16	5/16	
—	8	BR-M8-316	11/16	18мм	9/16	5/16	
3/8	—	BR-06-316	3/4	3/4	5/8	11/32	7/32
—	10	BR-M10-316	15/16	22мм	3/4	13/32	
1/2	12	BR-08-316	15/16	15/16	3/4	13/32	
5/8	15,16	BR-10-316	1	1 1/16	13/16	13/32	
3/4	18	BR-12-316	1 1/16	1 3/16	29/32	15/32	
7/8	—	BR-14-316	1 1/8	1 5/16	1 1/32	17/32	
1	—	BR-16-316	1 9/32	1 5/8	1 5/32	9/16	

- ❖ Включая соответствующие крепежные винты.

Тип 1 выхода	Размер 1 выхода	Обозначение конфигурации	Тип 2 выхода	Размер 2 выхода	Выходы 3 и 4	Материал
M Метрич. трубка	1 1/16"	MC Штуцер с внешней резьбой	Такой же как и 1 части ИЛИ: FNPT Внутренняя NPT	Такой как и 1 часть ИЛИ: 5 M5 x 0.8 или 5/16-24	Такие же как 1 выход	316 Нержавеющая сталь марки 316
F Дюйм. трубка	2 1/8" или 2 мм	VMS Штуцер с внешней резьбой и монтажом на панель	NPT Внутренняя NPT	6 M6 x 1 или 3/8-24		316L Нержавеющая сталь марки 316L
MT Метрич. трубный адаптер	3 3/16" или 3 мм	TC Фитинг с внешней резьбой для терморлар	NPT Внешняя NPT	7 7/16-20	304 Нержавеющая сталь марки 304	
FT Метрич. трубный адаптер	4 1/4" или 4 мм	FC Фитинг с внутренней резьбой	NPT Уплотнительные кольца из эластомеров Внешняя NPT	8 M8 x 1 или 1/2-20	304L Нержавеющая сталь марки 304L	
	5 5/16"	VFC Фланец с внутренней резьбой с креплением на панель	FBT Внутренняя FPT	9 9/16-18	A20 Сплав 20	
	6 3/8" или 6 мм	U Муфта	MBT Внешняя FPT	10 M10 x 1	A400 Сплав 400	
	8 1/2" или 8 мм	BU Муфта с монтажом на панель	MBTO Уплотнительные кольца из эластомеров с внешней FPT	12 M12 x 1.5 или 3/4-16	A600 Сплав 600	
	10 5/8" или 10 мм	ME Угольник с внешней резьбой	FBP Внутренняя FPT	14 M14 x 1.5 или 7/8-14	A825 Сплав 825	
	12 3/4" или 12 мм	#5ME Угольник под 45° внешней резьбой	PMBP Внешняя FPT (for BP)	16 M16 x 1.5	A276 Сплав C276	
	14 7/8" или 14 мм	PME Угольник с внешней резьбой	MBS Внешняя FPT (for BS)	17 1 1/16-12	DU7 Дуплекс 2507	
	15 15 мм	FE Угольник с внутренней резьбой	MBP Внешняя FPT (for BS)	18 M18 x 1.5	BR Латунь	
	16 1" или 16 мм	UE Соединительный угольник	FMS Внутренняя SO	19 1 3/16-12	CS Углеродистая сталь	
	18 1 1/8" или 18 мм	MRT Тройник с внешней резьбой сбоку Тройник с внешней резьбой снизу	MS Внешняя SO (for SO)	20 M20 x 1.5	TT Титан	
	20 1 1/4" или 20 мм	MBT Тройник с внешней резьбой сбоку Тройник с внешней резьбой снизу	BPMS Внешняя SO (for BP)	21 1 5/16-12		
	22 22 мм	PMBT Позиционируемый Тройник с внешней резьбой сбоку	BSMS Внешняя SO (for BS)	22 M22 x 1.5		
	24 1 1/2" или 24 мм	FRT Тройник с внутренней резьбой сбоку	OMS Уплотнительные кольца из эластомеров с внешней SO	24 M24 x 1.5		
	25 25 мм	FBT Тройник с внутренней резьбой снизу	FST Внутренняя AE	26 1 5/8-12		
	28 28 мм	UT Соединительный тройник	MST Внешняя AE (for BG)	27 M27 x 2		
	30 30 мм	UC Соединительная крестовина	BPST Внешняя AE (for BP)	30 1 7/8-12		
	32 2" или 32 мм	CA Колпак	BSST Внешняя AE (for BS)			
	38 38 мм	PL Заглушка	OST Уплотнительные кольца из эластомеров с внешней AE			
	50 50 мм	R Переходники с трубным адаптером	PPT Позиционируемые BSP Цилиндрическая резьба с внешней AE			
		PC Соединитель для фитингов	PMS Позиционируемые SO Цилиндрическая резьба			
		MA Трубный адаптер с внешней резьбой	PST Позиционируемые AE Цилиндрическая резьба			
		FA Трубный адаптер с внутренней резьбой	AN Резьба 370			
		WC Штуцер под приварку	FSW Под приварку вращающейся дюйма			
		WE Угольники под приварку	FBW Под приварку в стык дюйма			
		FLA Фланцевый переходник	MSW Под приварку вращающейся метрической			
		SFF Переходник с санитарию фланца				
		N Гайка				
		MN Гайки				
		RF Задние обжимные кольца				
		FF Передние обжимные кольца				
		FR Обжимные кольца				
		NFR Комплект обжимных колец и гаек				

